

Disc Brakes

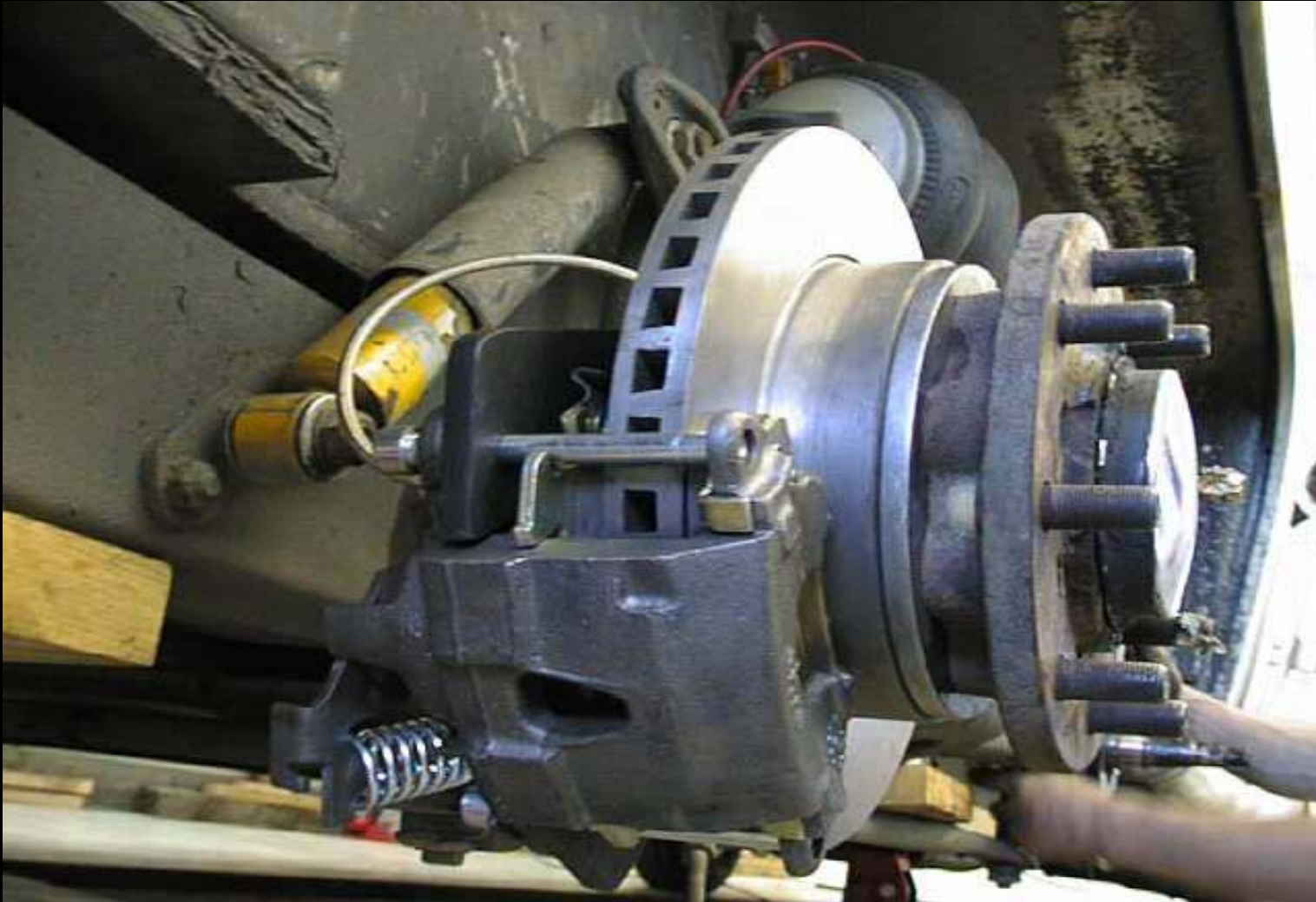

HOW ABOUT A GMC PARKING
AND EMERGENCY BRAKE ?

25/05/2011

61

Disc Brakes

- What are our options and what compromises do we have to accept when attempting to apply a park brake function in combination with rear disc brakes ?
- Presently in our GMC community we have generally the following disc brake configurations and perhaps others that I don't even know about.

Disc Brakes

- Large Tornado type calipers on the intermediate bogies and drums on the rear bogies.
- Large Tornado type calipers on the intermediate bogies and smaller Eldorado calipers on the rear with park brake feature.
- Large Eldorado type calipers on the intermediate and rear bogies with park brake feature on both.

Disc Brakes

- What's the best combination when considering "service braking" ability in combination with park brake ability and possibly limited emergency braking ?
- Research and testing over the past two years has basically pointed to the following: If one desires 6 wheel disc brakes AND a reliable and effective parking brake , the following points must be addressed

HOW ABOUT A GMC PARKING
AND EMERGENCY BRAKE ?

Disc Brakes

- There's no disputing that discs provide the best "**service braking**", they run cooler, are mechanically much simpler and easier to do maintenance on than drum brakes. **HOWEVER:** As far as providing a parking brake function or mechanical emergency brake function; Few PB calipers are up to the task of holding a 12,000 lb. vehicle stationary on a 10% grade

Disc Brakes

- In consultation with the folks at Cinnabar and Skip at TSM Brakes, I have been unable to find out the clamp force exerted by the park brake function of the caliper. None of them know. I would consider this information a bare minimum when it comes to setting a baseline for park brake performance and evaluation with regards to the Eldorado type calipers.

Disc Brakes

- TSM Eldorado Type caliper. 10,000 lbs. hydraulic clamp force, mechanical unknown
- Hayes ball and ramp caliper, 10,000 lbs clamp force, hydraulic **and** mechanical



HOW ABOUT A GMC PARKING
AND EMERGENCY BRAKE ?

Disc Brakes

The Hayes 1-663-1SA Caliper:

Mechanical Park Brake Information:

- Max. lever force @ 4.375"450 lbs.
- Lever stroke for 10,000 lbs. of clamp.....27 degrees, or 2.113 inches.
- Lever positions.....30 degree increments

Hydraulic Information:

- Piston Diameter.....2.6 inches or 66 mm
- Max. hydraulic pressure.....2000 psi

Disc Brakes

- **The Hayes 1-663-1SA Caliper:**

In all fairness the above Hayes caliper will not work on our coaches ; it will not fit inside an Alcoa wheel. The information simply illustrates that some manufactures do supply this data to their customers and that this data is a must for baseline analysis for calculating park brake requirements.

Disc Brakes

- The following info on the calipers would be most beneficial:

A/ Clamp force as a function of degrees rotation of the PB lever.

B/ Pounds of pull force on the caliper lever to achieve a specific clamping force.

C/ Cable pull distance to achieve a specific clamping force.

D/ Degrees of thread pitch on caliper lever lead screw or ball and ramp mechanical advantage.

Disc Brakes

- Since the aforementioned data seemed to be non-existent , there appeared to be no alternative except to gather the data the hard way! Do it yourself !
- Approximately 14 months ago , I began harvesting park brake (PB) calipers from wrecking yards and building up a " test bed" to test them.

Disc Brakes

Since the first power point presentation back in 2006, I've been aware of the large Hayes hydraulic / mechanical calipers from Hayes Performance Systems up in Wisconsin but basically dismissed them due to the fact that they were " Off Road" and they were too large physically to fit inside an Alcoa wheel as well as being relatively expensive. Had the good fortune to talk to a brake guru at TRW in Livonia , MI and he suggested testing the old Lincoln MK V rear caliper

Disc Brakes

The following slides are a pictorial of the tests done Jan / Feb 2010, on the Kelsey Hayes / Bendix PB caliper and the large Caddy Eldorado PB caliper, both calipers are of the same era, ie. 1975 to 1979 Lincolns , Thunderbirds and Cadillacs respectively

Disc Brakes

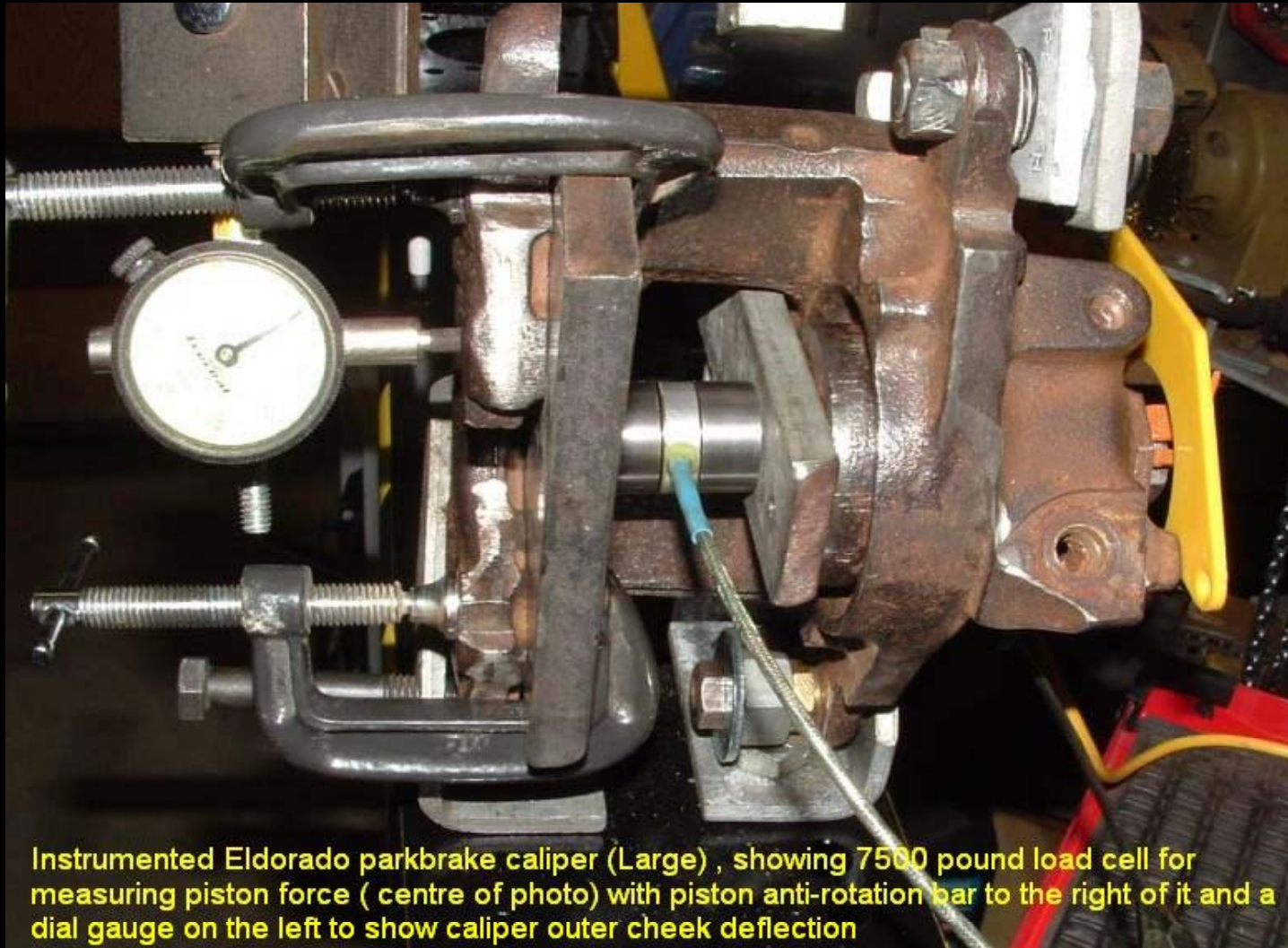

Instrumented Eldorado parkbrake caliper (Large) , showing 7500 pound load cell for measuring piston force (centre of photo) with piston anti-rotation bar to the right of it and a dial gauge on the left to show caliper outer cheek deflection

HOW ABOUT A GMC PARKING
AND EMERGENCY BRAKE ?

Disc Brakes



Viewing Eldorado caliper bridge with piston anti-rotation bar protruding thru it . The bar is 3/8" X 1-1/2" X 6" steel . Two 1/4" pins in the bar mate into the piston holes to prevent rotation during testing.

NOW ABOUT A GMC PARKING
AND EMERGENCY BRAKE ?

25/05/2011

75

Disc Brakes



Lever side view of Eldorado caliper showing degrees rotation measurement of lever and linear potentiometer to measure lever travel in inches

25/05/2011

HOW ABOUT A GMC PARKING AND EMERGENCY BRAKE ?

76

Disc Brakes

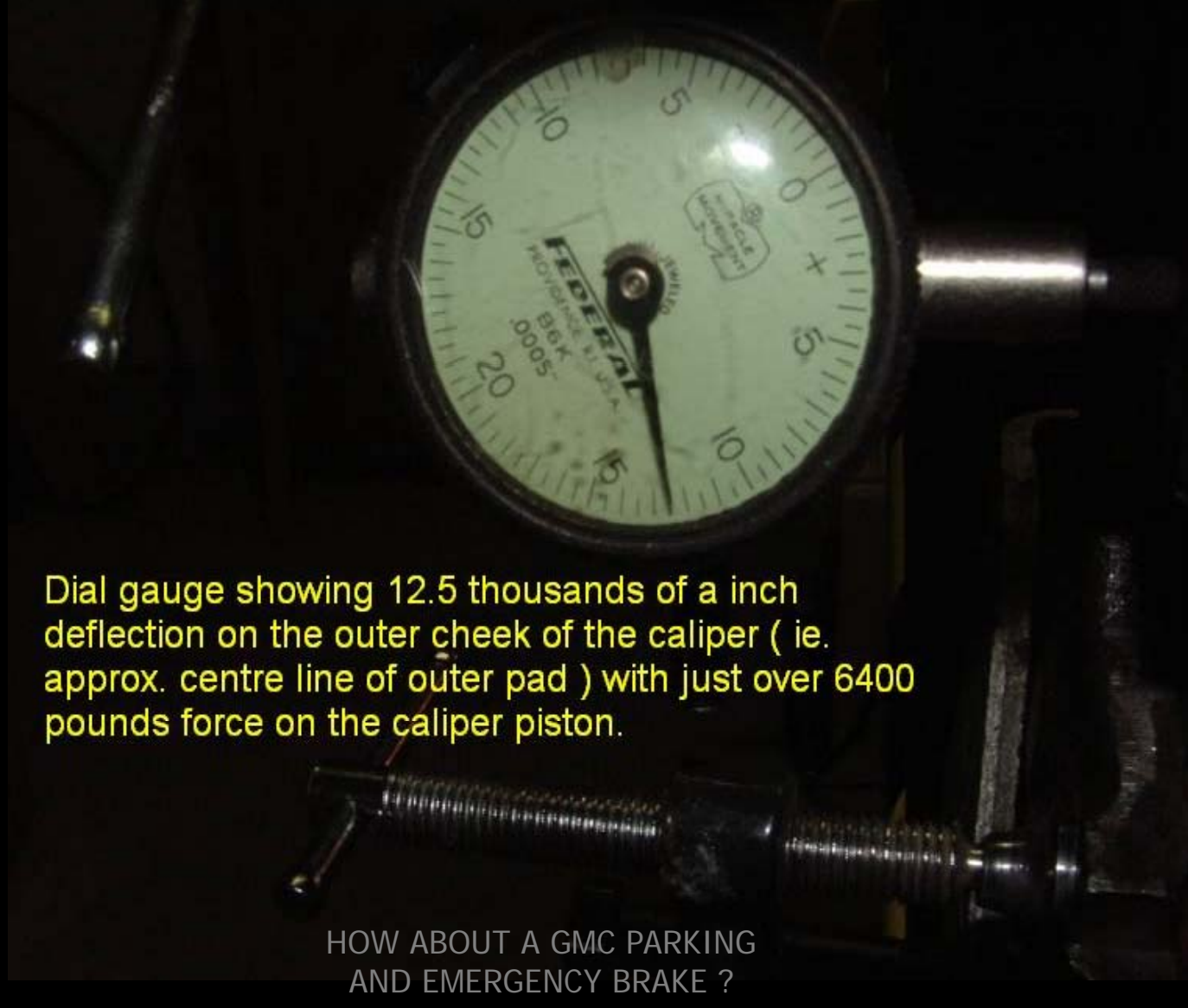

Dial gauge showing 12.5 thousands of a inch deflection on the outer cheek of the caliper (ie. approx. centre line of outer pad) with just over 6400 pounds force on the caliper piston.

Disc Brakes

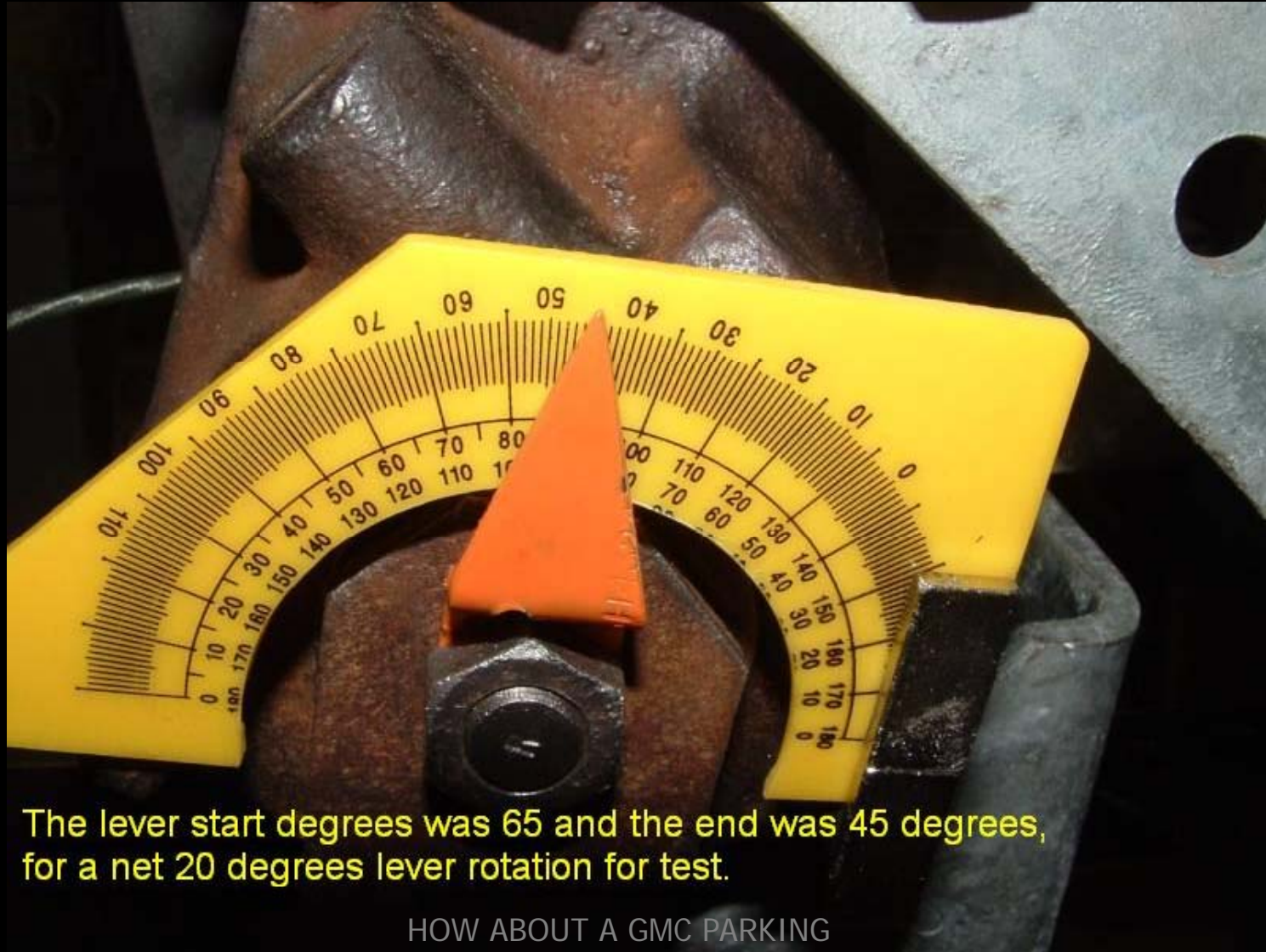

The lever start degrees was 65 and the end was 45 degrees, for a net 20 degrees lever rotation for test.

HOW ABOUT A GMC PARKING
AND EMERGENCY BRAKE ?

Disc Brakes

Lever travel in inches on the Eldorado caliper (Large) ,Lever travel in inches on the Eldorado caliper (Large) ,

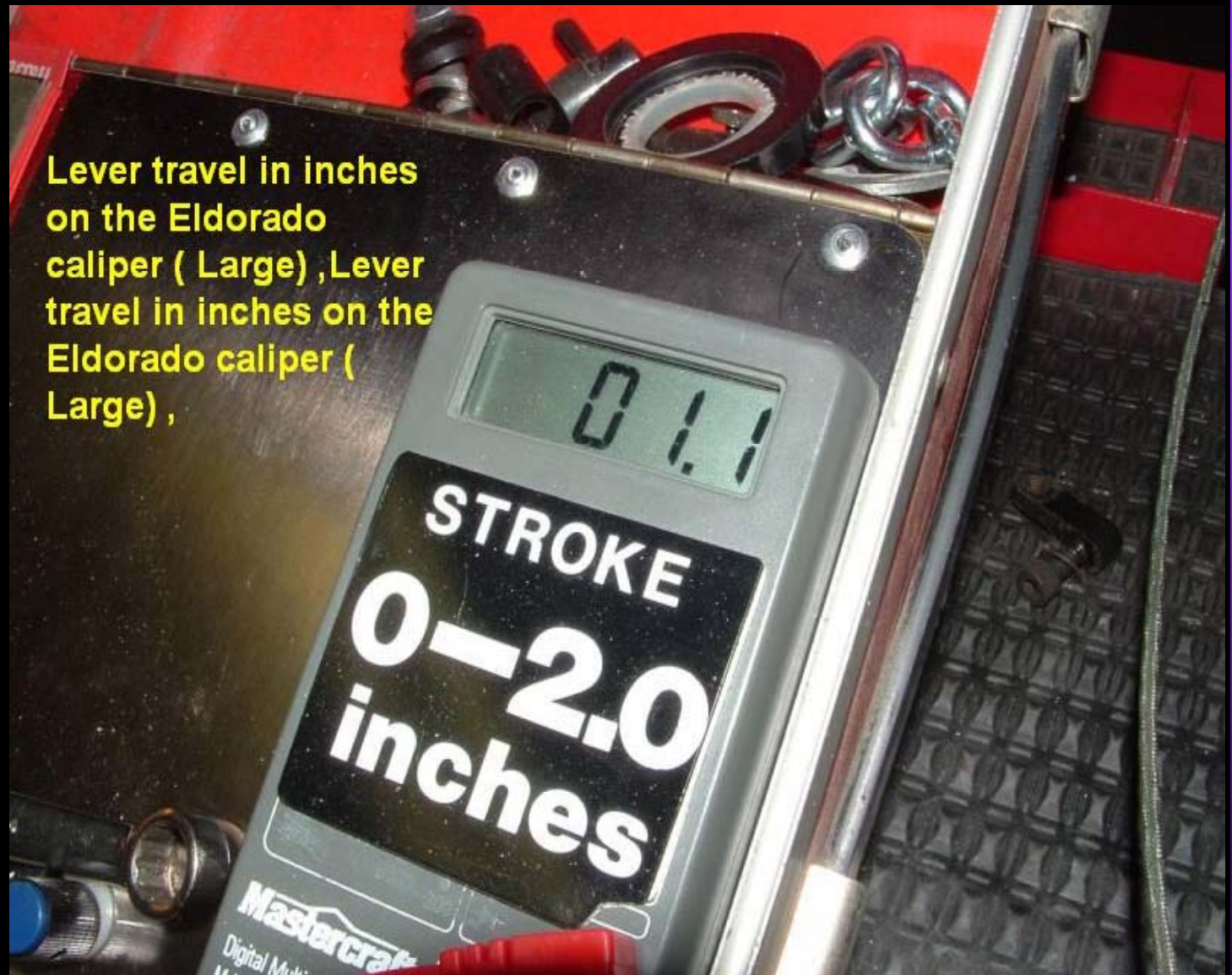

Disc Brakes



HOW ABOUT A GMC PARKING
AND EMERGENCY BRAKE ?

Disc Brakes

Caliper test bed, aircraft tensiometer test / calibrator at left of photo, Eldorado caliper mounted in center and S- Load cell for measuring lever pull force at right of photo. Readout modules are in the red cases.



HOW ABOUT A GMC PARKING
AND EMERGENCY BRAKE ?

Disc Brakes

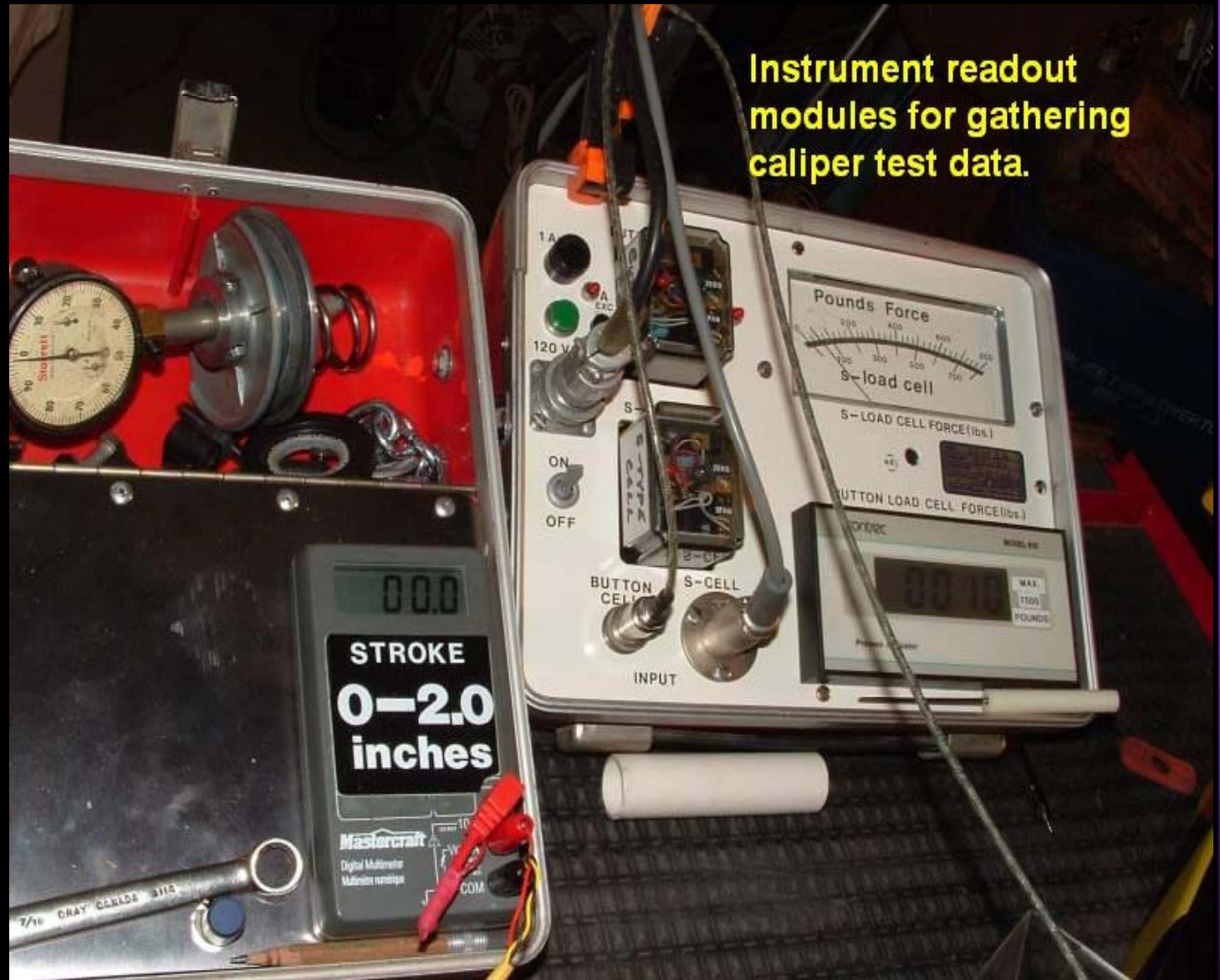

Instrument readout modules for gathering caliper test data.

HOW ABOUT A GMC PARKING AND EMERGENCY BRAKE ?

Disc Brakes

700 pound S-Type load cell for measuring lever pull force on caliper. Pull force applied by tightening turnbuckle.

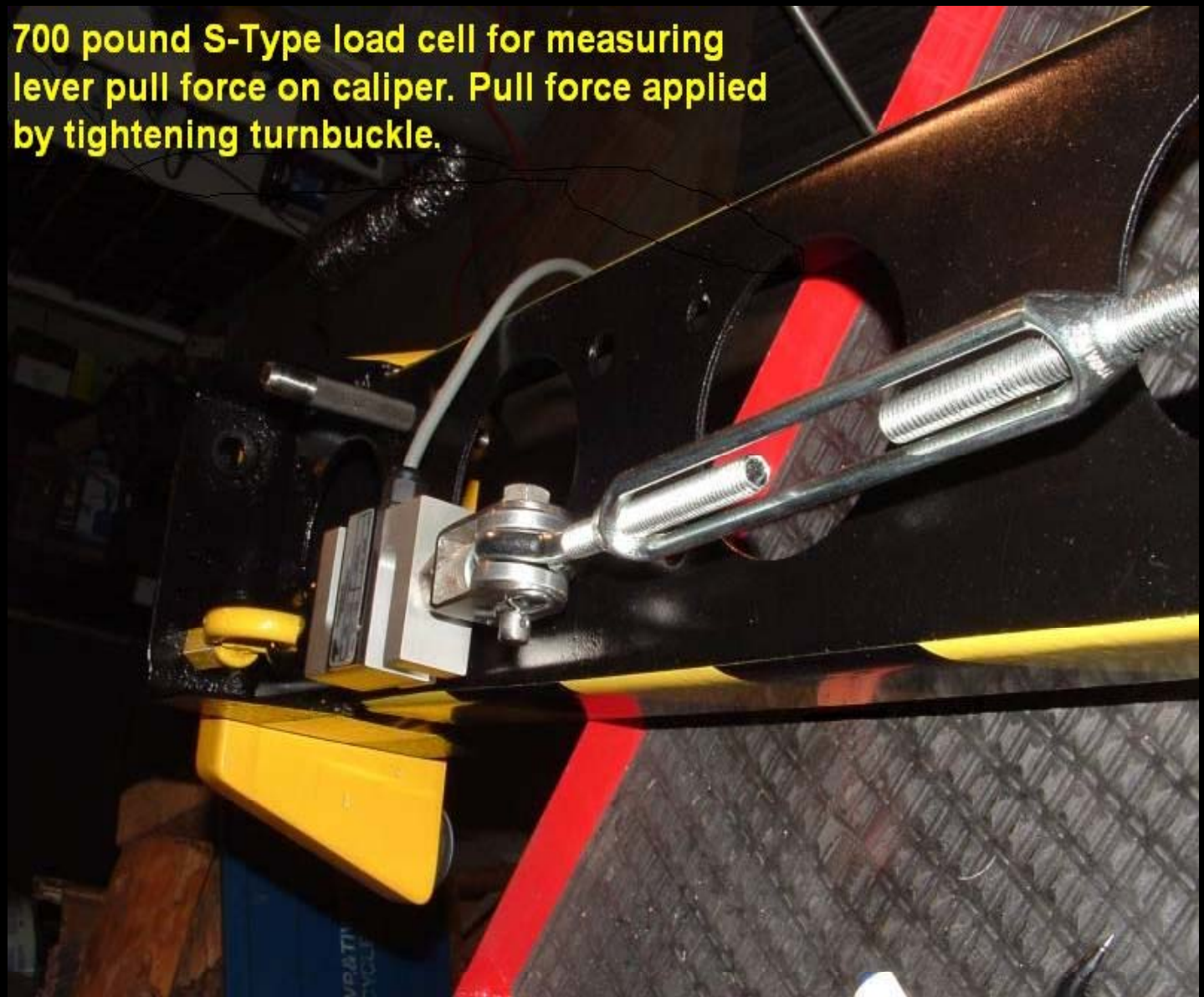

HOW ABOUT A GMC PARKING
AND EMERGENCY BRAKE ?

25/05/2011

83

Disc Brakes

Cylinder for test and calibration of Burroughs Aircraft Tensiometers.



HOW ABOUT A GMC PARKING
AND EMERGENCY BRAKE ?

25/05/2011

84

Disc Brakes

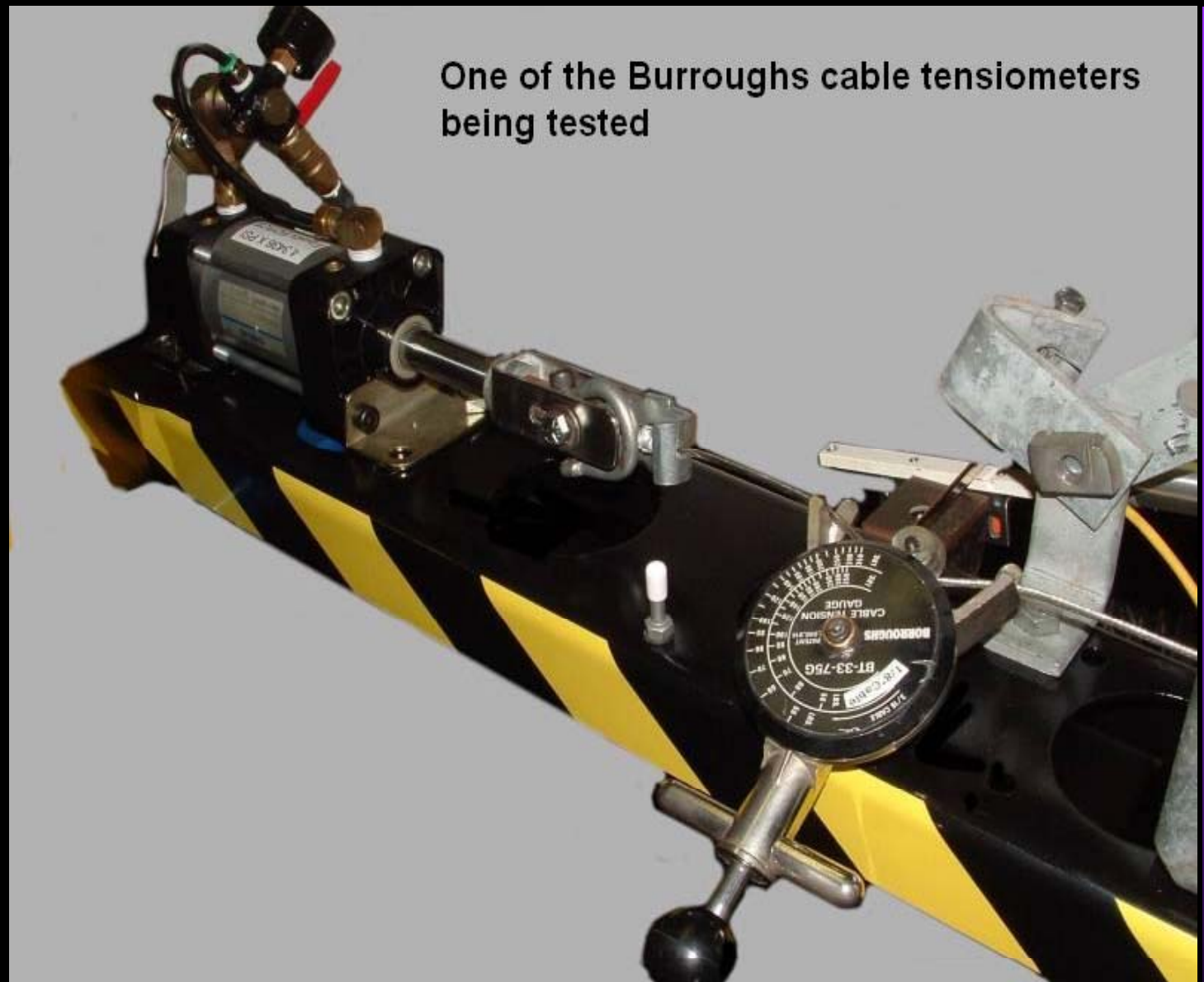

25/05/2011

HOW ABOUT A GMC PARKING
AND EMERGENCY BRAKE ?

85

Disc Brakes

Calibration and test rig for 7500 pound button load cell for measuring caliper piston force.



HOW ABOUT A GMC PARKING AND EMERGENCY BRAKE ?

Disc Brakes

Hayes Brake automotive type caliper (HBA) mounted up side down on test bed. Lever travel potientometer on lower left, degrees lever rotation in yellow and 7500 pound load cell against the piston. Bent the 1/2" piece of steel where the outer pad would go ! Had to go to a 3/4" thick piece



25/05/2011

HOW ABOUT A GMC PARKING
AND EMERGENCY BRAKE ?

87

Disc Brakes

HBA caliper with 10 thousands of a inch deflection on the outer cheek with a piston force of over 6000 pounds. The deflection was measured at centre line of the outer pad



25/05/2011

HOW ABOUT A GMC PARKING
AND EMERGENCY BRAKE ?

88

Disc Brakes

HBA caliper on test and with 25 degrees rotation on its lever. Both HBA and the Eldorado levers were 3.20 inches in effective length to avoid comparing apples to oranges (or perhaps lemons ???)



25/05/2011

HOW ABOUT A GMC PARKING
AND EMERGENCY BRAKE ?

89

Disc Brakes

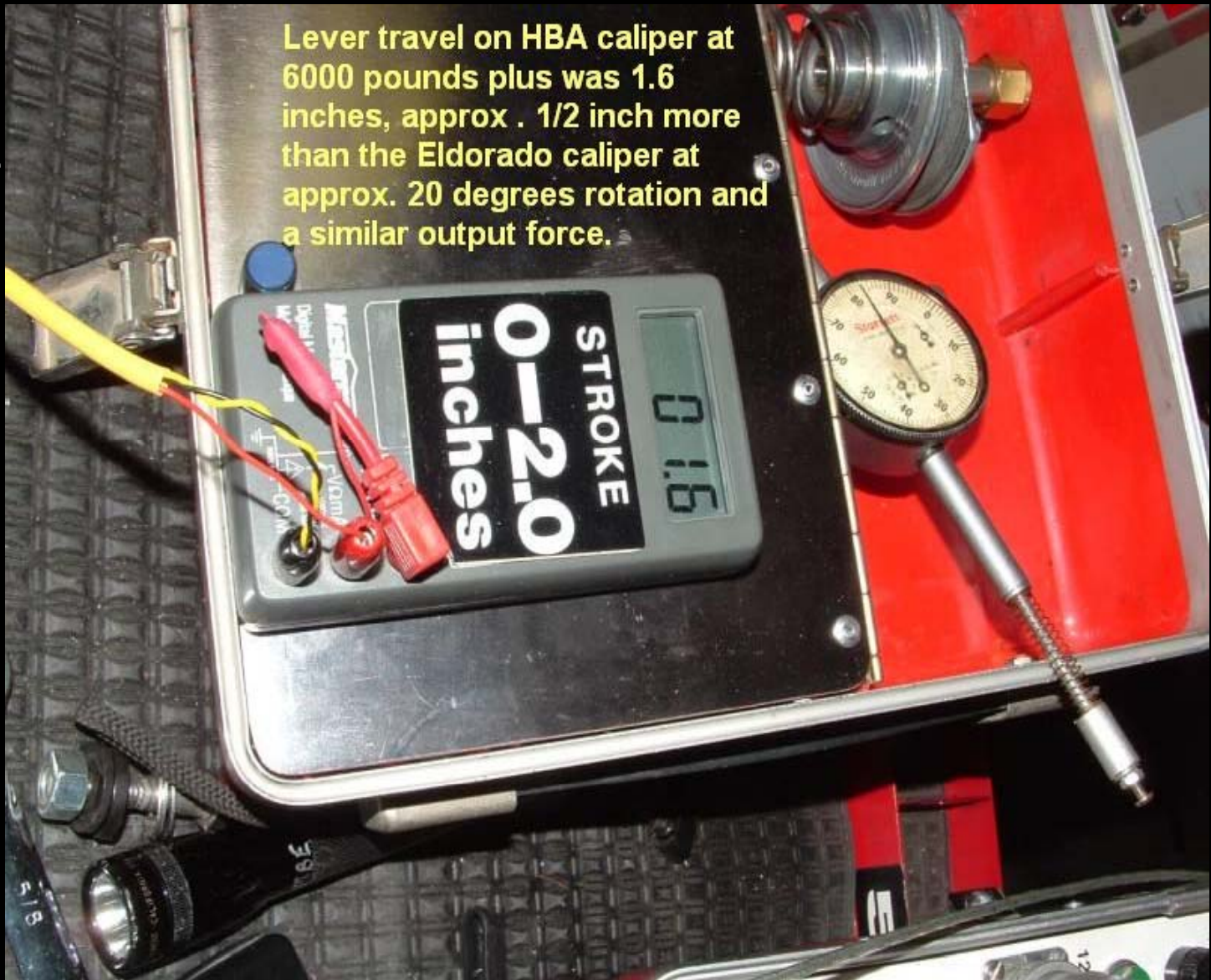

Lever travel on HBA caliper at 6000 pounds plus was 1.6 inches, approx . 1/2 inch more than the Eldorado caliper at approx. 20 degrees rotation and a similar output force.

HOW ABOUT A GMC PARKING AND EMERGENCY BRAKE ?

Disc Brakes

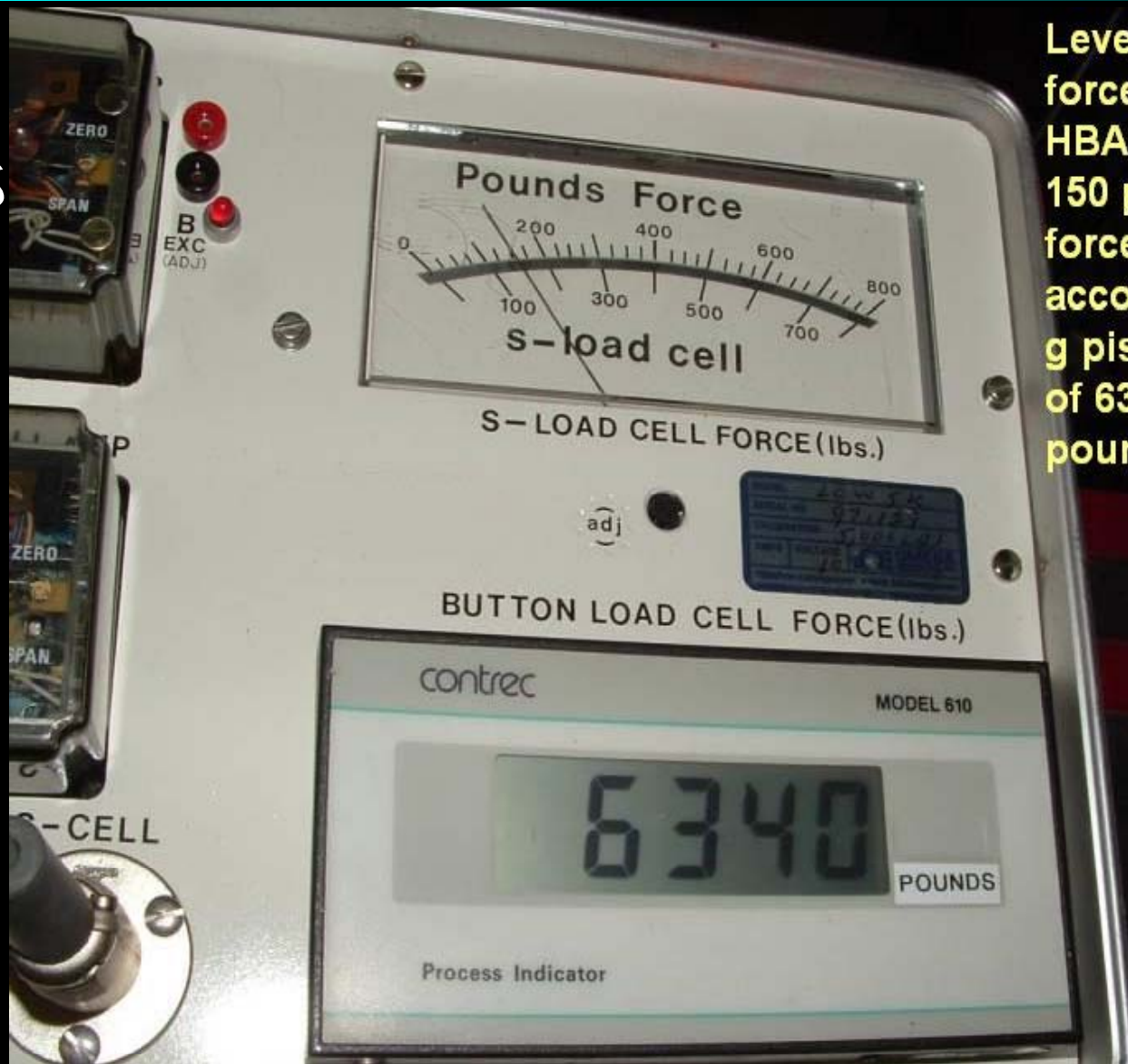

Lever pull force on the HBA caliper at 150 pounds force and an accompanying piston force of 6340 pounds.

HOW ABOUT A GMC PARKING AND EMERGENCY BRAKE ?

Disc Brakes

HBA DISC CALIPER TESTING DATA, JAN 04, 2010
Lever length = 3.200 "

Lever Rotation in Degrees	Lever Travel in Inches	Caliper body deflection in thou.	Lever pull force in pounds	Caliper piston force in pounds	Caliper piston travel in thou.
0	0	0		0	0
2.5					
5	0.4	1.75	65	1390	14
7.5					
10	0.8	4.5	125	3170	24
12.5					
15	1	6.5	145	4380	31
17.5					
20	1.3	8.5	130	5290	36
22.5					
25	1.6	9.5	130	6340	39
27.5					
30					
32.5					
35					

ELDORADO (Large 2.5") DISC CALIPER TESTING DATA, JAN 14, 2010
Lever length = 3.200 "

Lever Rotation in Degrees	Lever Travel in Inches	Caliper body deflection in thou.	Lever pull force in pounds	Caliper piston force in pounds	Caliper piston travel in thou.
0	0	0	0	0	0
2.5					
5	0.279	2.5	80	1250	12.3
7.5					
10	0.558	7	215	3050	24.6
12.5					
15	0.837	10.5	360	5050	36.9
17.5					
20	1.116	11.5	425	6030	49.2
22.5					
25	1.211	12.5	470	6460	59
27.5					
30					
32.5					
35					

NOTES:
Test data sheet for the Eldorado (Large) parkbrake caliper and the HBA caliper . HBA caliper piston dia. is 2.60" and the Eldorado piston is 2.5" dia.

HOW ABOUT A GMC PARKING AND EMERGENCY BRAKE ?

Disc Brakes

Internal components of Eldorado 2.5" dia. ; (Large) park brake



Internal components of Eldorado park brake caliper

HOW ABOUT A GMC PARKING
AND EMERGENCY BRAKE ?

Disc Brakes

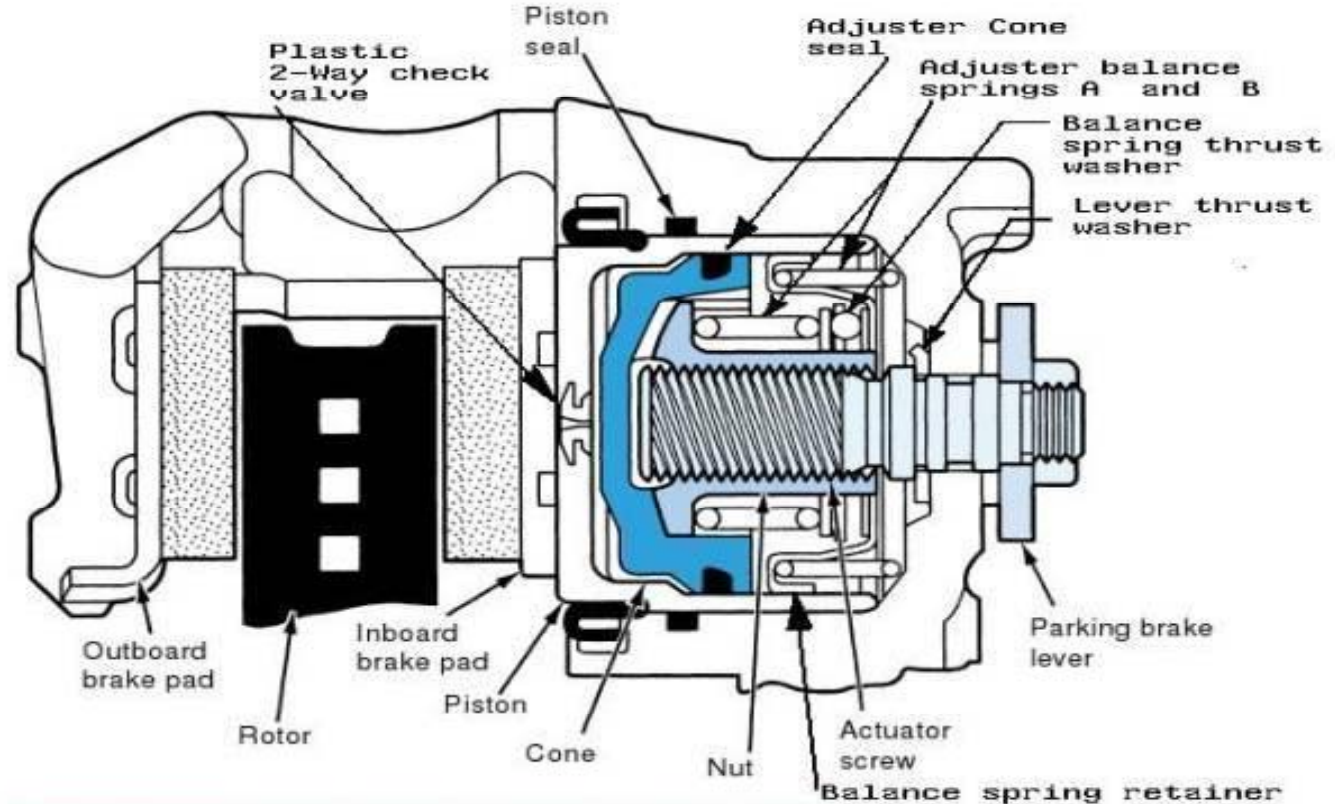

Figure 8-16 A GM screw-and-nut parking brake mechanism
(General Motors Corporation, Service Operations)

NOTE: Service and park brake adjuster function are both dependent upon regular use of the park brake. The automatic adjuster only functions when the park brake lever is routinely rotated and a 0.030" gap is present between the brake pad and rotor.

Pictorial of internal components of Eldorado

Disc Brakes

Internal components of 2.6" HBA park brake caliper



HBA Park Brake caliper internal components

HOW ABOUT A GMC PARKING
AND EMERGENCY BRAKE ?

Disc Brakes

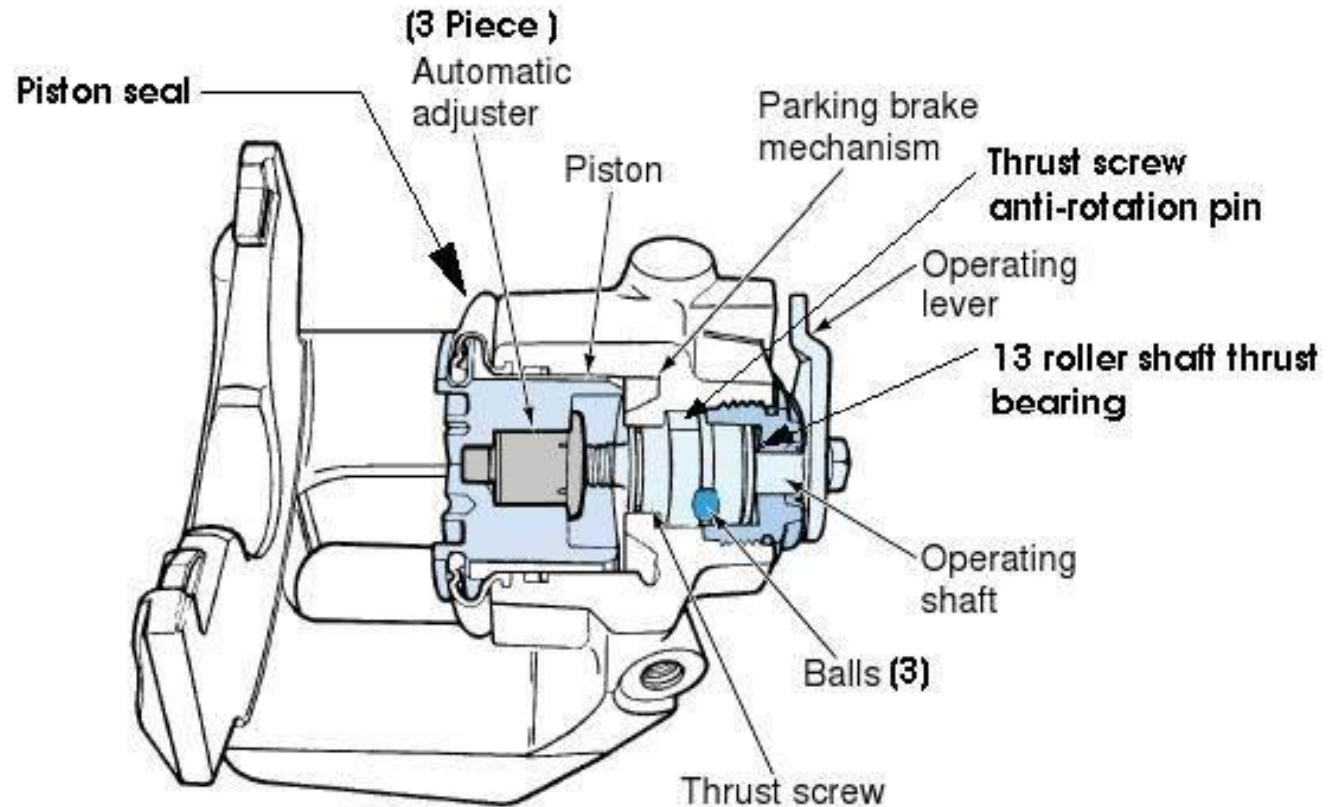

Kelsey - Hayes ball and ramp park brake caliper. Theoretical brake ratio 8 thru 30. Auto adjustment for pad wear via service brake at 0.020" gap. Park brake mechanism sealed from hydraulic chamber via thrust screw O-ring seal. Capable of over 10,000 Lb. clamp on brake rotor at 150 Lb. pull on park brake lever. (Hayes Brake Automotive Div.- HBA)

HOW ABOUT A GMC PARKING
AND EMERGENCY BRAKE ?

Disc Brakes

Put together a couple of crude (but accurate) inclinometers , calibrated on a dead flat surface and set out with the car to find a steep incline or two

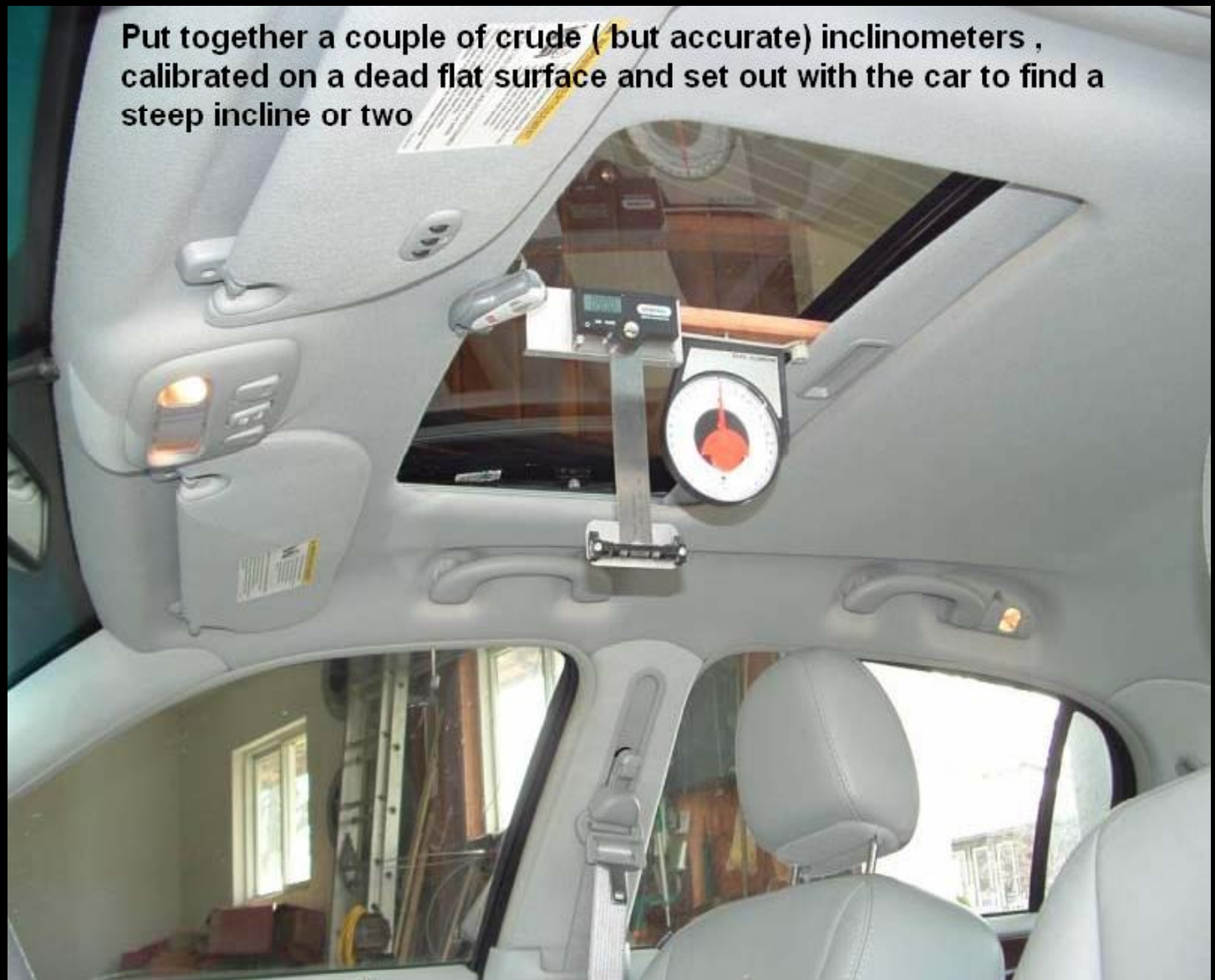

HOW ABOUT A GMC PARKING
AND EMERGENCY BRAKE ?

Disc Brakes

Closer view of the inclinometers



25/05/2011

HOW ABOUT A GMC PARKING
AND EMERGENCY BRAKE ?

98

Disc Brakes



Sheila doing her magic with the traffic cones, there's a real danger out here of getting run over with a big cattle truck.

25/05/2011

HOW ABOUT A GMC PARKING
AND EMERGENCY BRAKE ?

99

Disc Brakes



We think this hill will fit the bill.

HOW ABOUT A GMC PARKING
AND EMERGENCY BRAKE ?

Disc Brakes

Sheila on the far side of the hill retring the traffic cones.



25/05/2011

HOW ABOUT A GMC PARKING
AND EMERGENCY BRAKE ?

101

Disc Brakes

The same gulch as previously shown but perpendicular to it and unpaved. Did forward and back measurements here as well. Coach held stationery at 7 out of 10 turns on the PB handle. No power assist



HOW ABOUT A GMC PARKING
AND EMERGENCY BRAKE ?

25/05/2011

102

Disc Brakes

- K-H Calipers were fitted to our coach prior to the DuQuoin, IL rally and the actual tests on the 12 % grades were completed on our return home from the rally. The power assist actuator was active at DuQuoin and possibly clouded the tests while there. The actuator was disabled for the tests on the hills. PB handle was set at 7 out of 10 turns.

Summary of K-H & Eldorado Outputs

- **Eldorado Caliper Output :**
- 6000 Lbs. Piston force (12,000 lbs. clamp)
- 1.2" pull distance on 3.2" lever
- 465 Lbs. pull on lever

- **Kelsey Hayes Caliper Output :**
- 6000 Lbs. Piston force (12,000 lbs. clamp)
- 1.6" pull distance on 3.2" lever
- 145 Lbs. pull on lever

Summary of K-H & Eldorado Outputs

- As can be seen , the Eldorado caliper requires just over 3 times the pull force on the lever as the Kelsey Hayes caliper for the same output force thus requiring some sort of power assist to enable a useful output. I was surprised to observe that it took approx. 70% of the output of the KH caliper to hold our 11,000 lb. Birchaven on a 13% slope

Summary of K-H & Eldorado Outputs

- As also can be seen; the KH caliper required approx. $\frac{1}{2}$ " longer pull distance per caliper than did the Eldorado and this requires some distance multiplication on the cable system. The OEM park brake handle cable travel is limited to $2 - \frac{3}{8}$ ". Jim K. has complained to me about "short stroke problems" It just occurred to me, he was talking about the park brake handle cable.

Example of cable distance multiplication

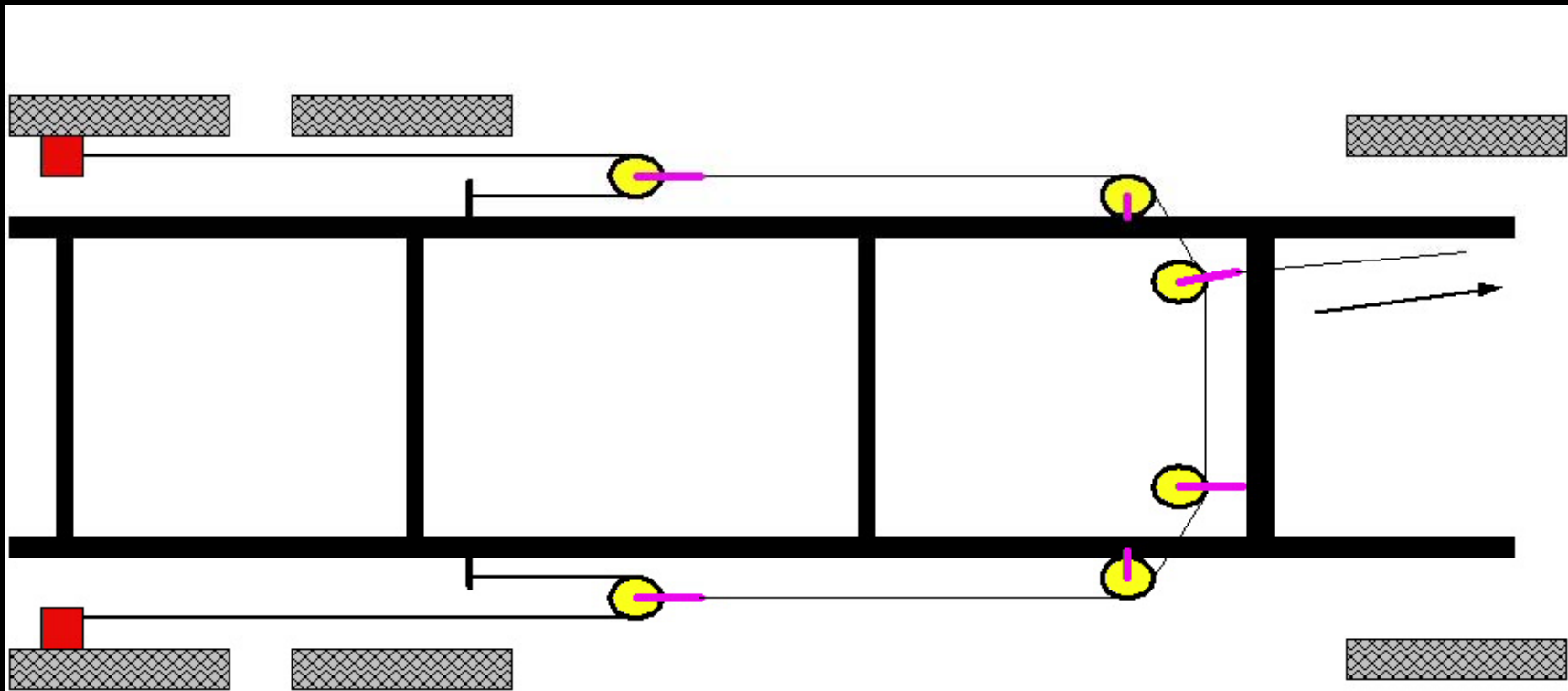

Example of cable distance multiplication

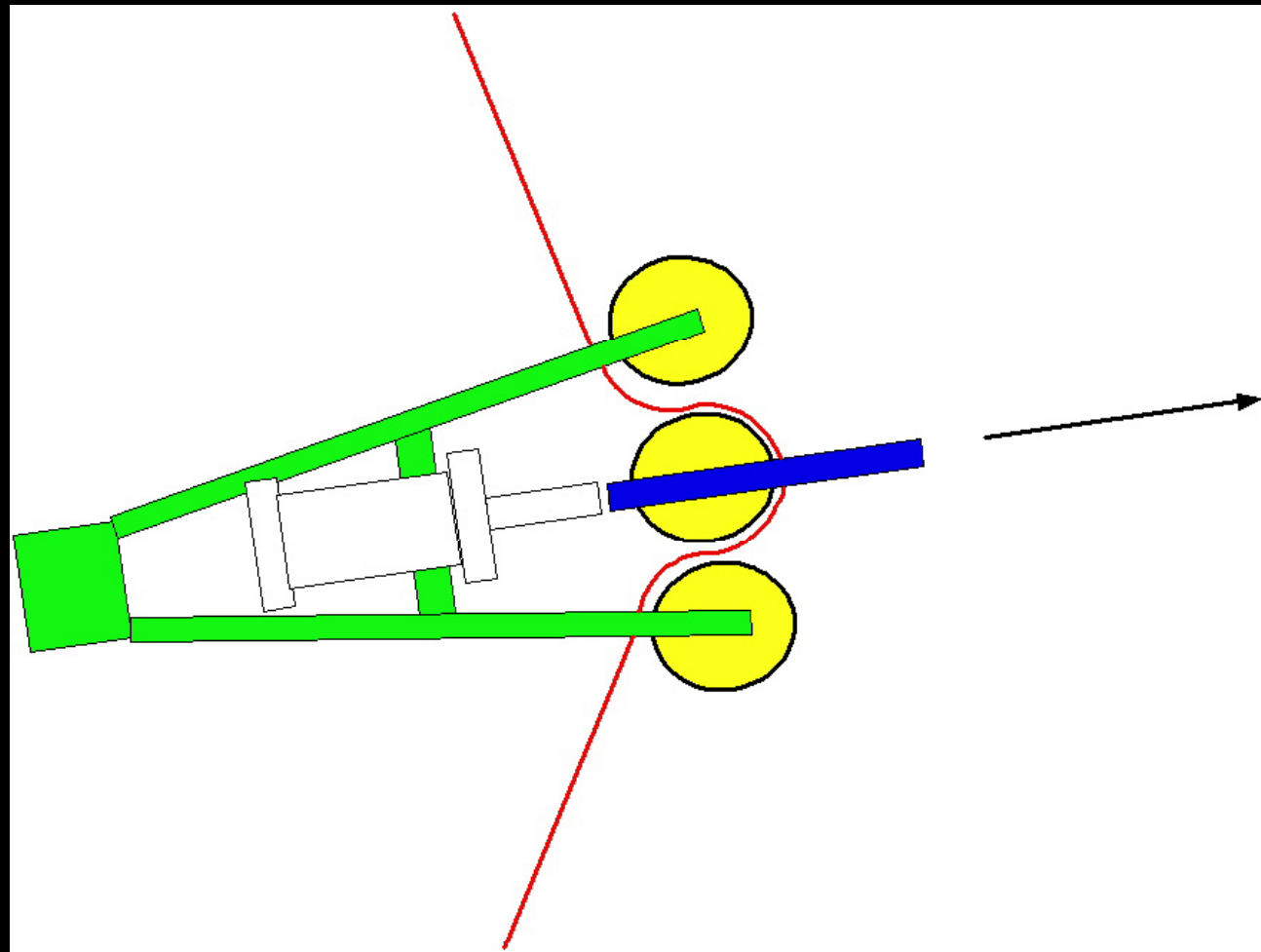

HOW ABOUT A GMC PARKING
AND EMERGENCY BRAKE ?

Example of cable distance multiplication

- In reference to the two prior drawings, Jim K. and Rick F. are working on a park brake handle modification that will provide more stroke and a longer handle will give a higher mechanical advantage. The second drawing is what we have presently on our coach and it could incorporate an air assist cylinder at a relatively moderate cost if it were necessary for convenience.

HOW ABOUT A GMC PARKING
AND EMERGENCY BRAKE ?

The Kelsey Hayes / Bendix PB Caliper

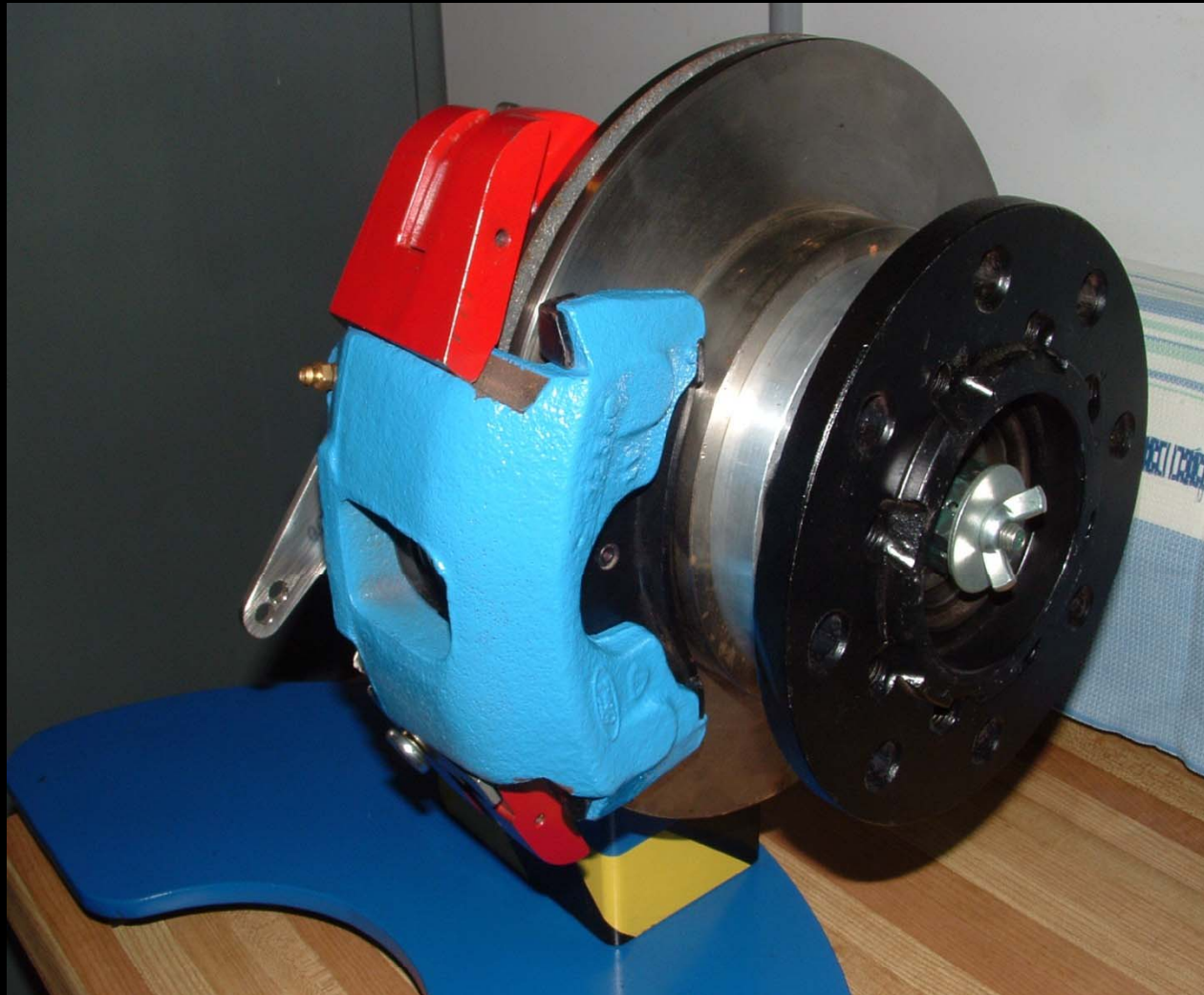

HOW ABOUT A GMC PARKING
AND EMERGENCY BRAKE ?

25/05/2011

110

The Kelsey Hayes / Bendix PB Caliper

- I have harvested 13 of the KH calipers from various wrecking yards to see what damage they had suffered over a 30 + year period, 3 had mild lever shaft corrosion due to bad seals and 5 had piston damage for the same reason. In no case was the " ball-ramp" mechanism damaged nor was the adjuster mechanism damaged at all.

The Kelsey Hayes / Bendix PB Caliper

After beating the bushes for weeks, I found a supplier for the pistons and associated seal kits. John at Goldline Caliper rebuilders in Seattle WA has pistons and will rebuild the calipers.

The photo to the right shows 11 pistons that were manufactured about a month ago in a plant about 30 miles north of Toronto, CAN.

The KH caliper appears virtually "Bullet Proof" and any damage they do suffer can be addressed.



HOW ABOUT A GMC PARKING
AND EMERGENCY BRAKE ?

The Kelsey Hayes / Bendix PB Caliper

- Some of the features of the K-H caliper
- 2.6 " dia. Piston (66 mm)
- Hyd. Force @1K PSI = 5310 Lbs.
- Mechanical force @ 150 lb. pull = 6000 lbs.
- Auto Adjust via service brake application
- Variable rate " ball ramp" actuation with an MA of approx. 20 to 40
- "Ball ramp" chamber isolated from brake fluid chamber

HOW ABOUT A GMC PARKING
AND EMERGENCY BRAKE ?

The Kelsey Hayes / Bendix PB Caliper

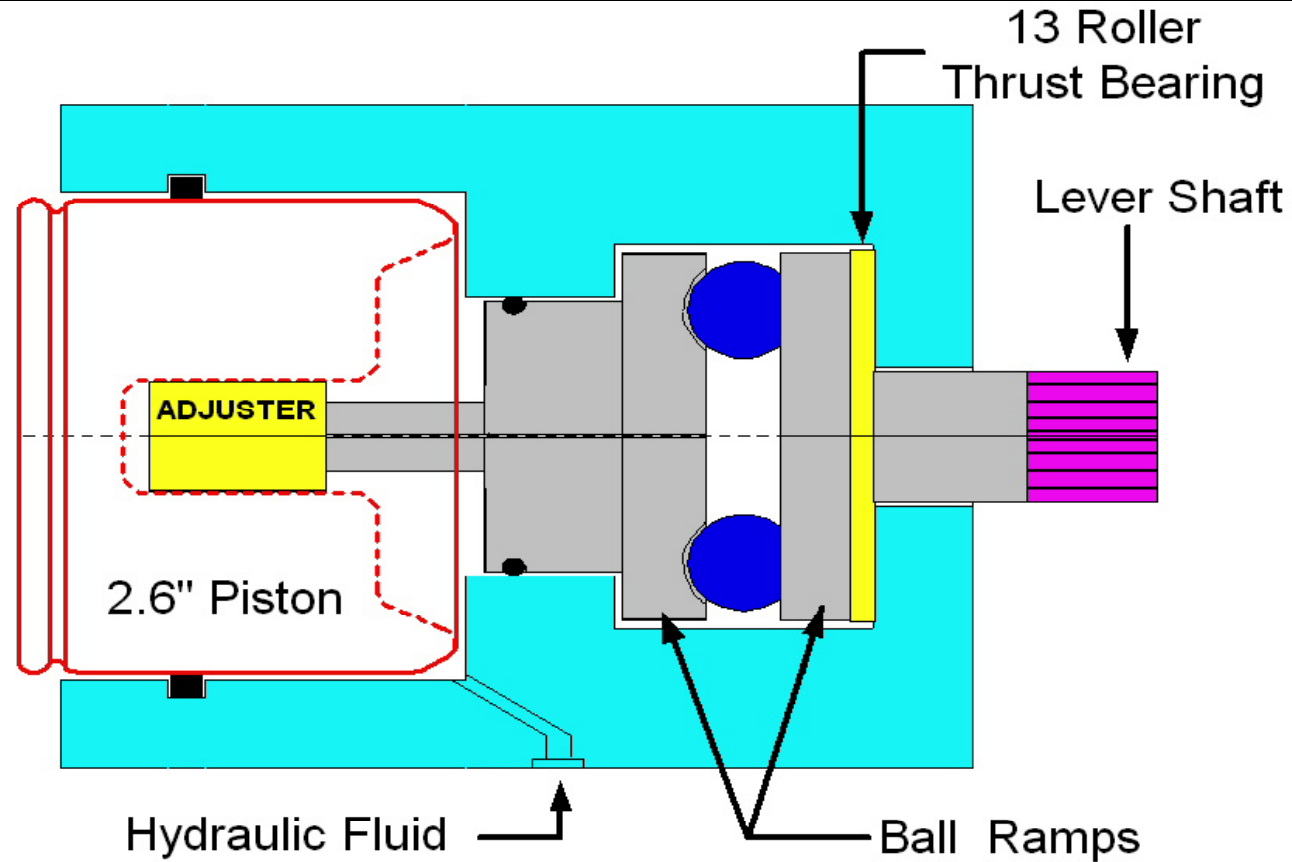

KELSEY HAYES / BENDIX PARK BRAKE CALIPER INTERNALS

HOW ABOUT A GMC PARKING
AND EMERGENCY BRAKE ?

The Kelsey Hayes / Bendix PB Caliper

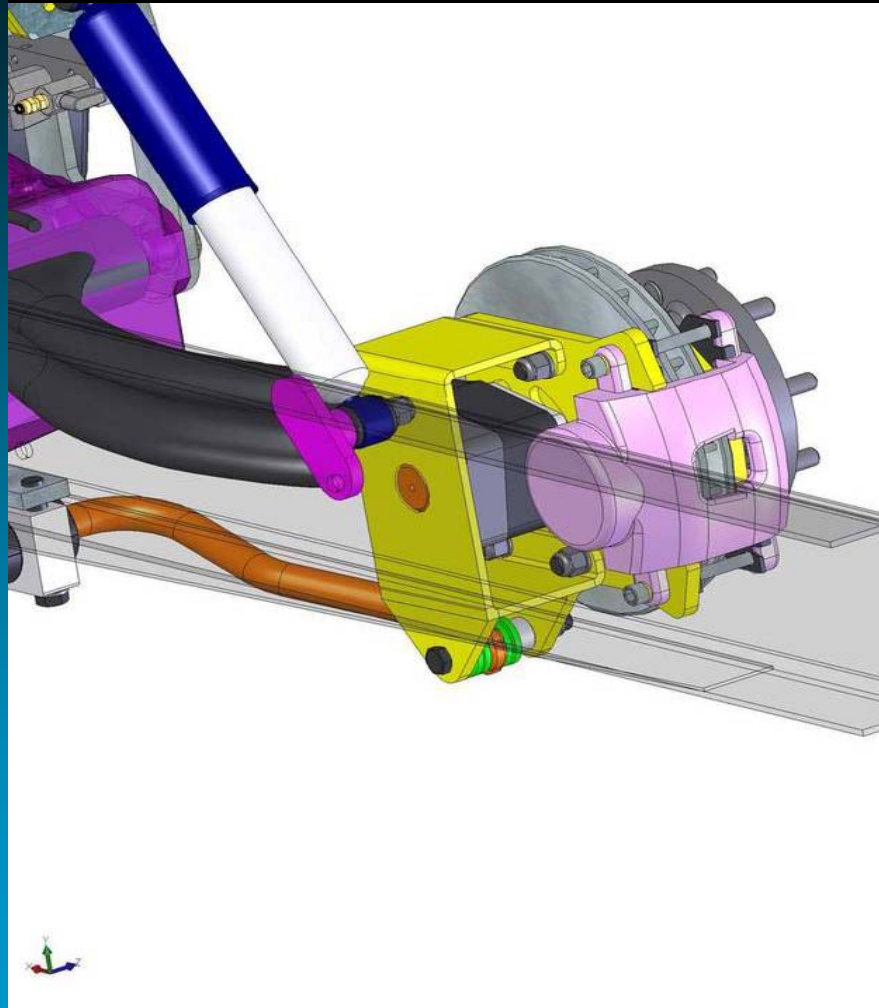

- The Reaction Arm brake system was another reason to look for a PB caliper that could be used without power assist and was a bit more user friendly and reliable than the Eldorado PB caliper

The Kelsey Hayes / Bendix PB Caliper

- When Kelsey Hayes was split up into a number of companies in the '80's , the new companies all maintained the original " ball-ramp" patents and applied them to new generations of brake calipers, some of the companies are: TRW, Bendix, Hayes Performance Systems , AM General (H1 / A1 Hummer) to name a few.

The Kelsey Hayes / Bendix PB Caliper

Photo of the HI / A1 Hummer caliper , this caliper is huge !
Measuring 9 – 3/8" in length , 2" longer than the KH or Eldorado and it would still require a custom mount for the GMC . Cost was also a factor in that they list for about \$400.00 each not including mounts

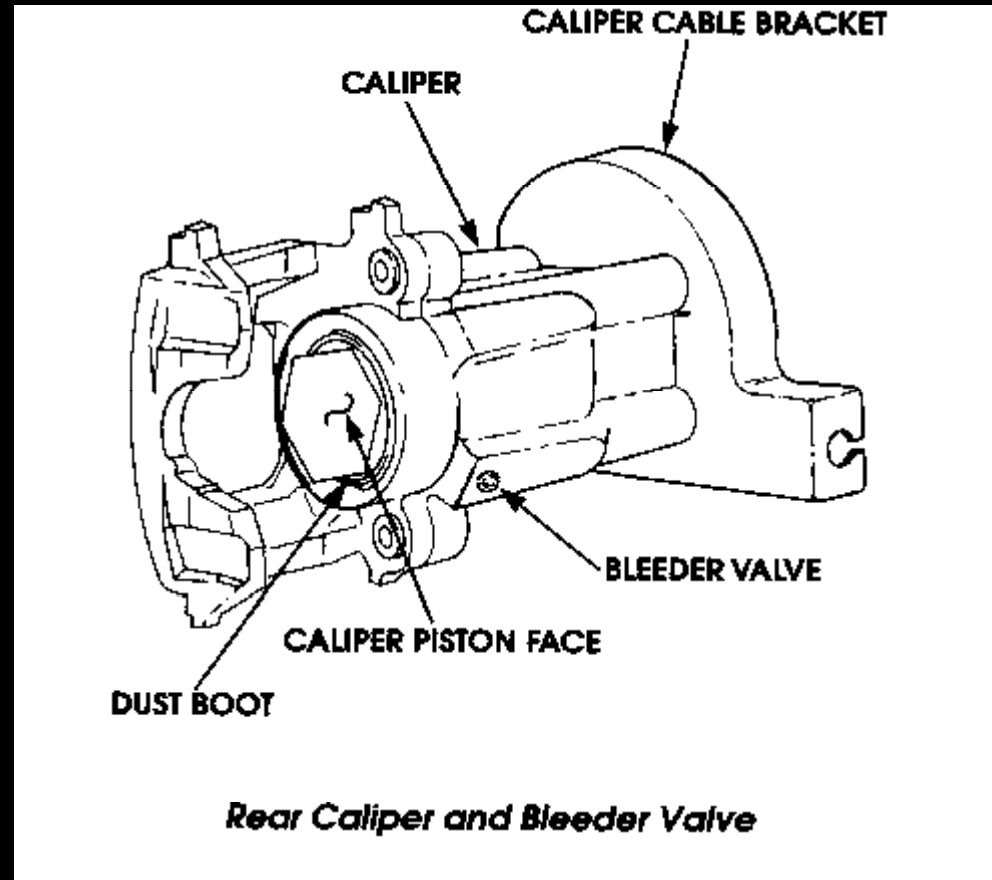

HOW ABOUT A GMC PARKING
AND EMERGENCY BRAKE ?

The Kelsey Hayes / Bendix PB Caliper

TRW Integrated Park brake caliper, showed some promise but upon further reasearch found out it maxed out at 45mm in piston diameter and was only rated for vehicles up to 3300 lbs. , it is also of the original Kelsey Hayes ball ramp design.

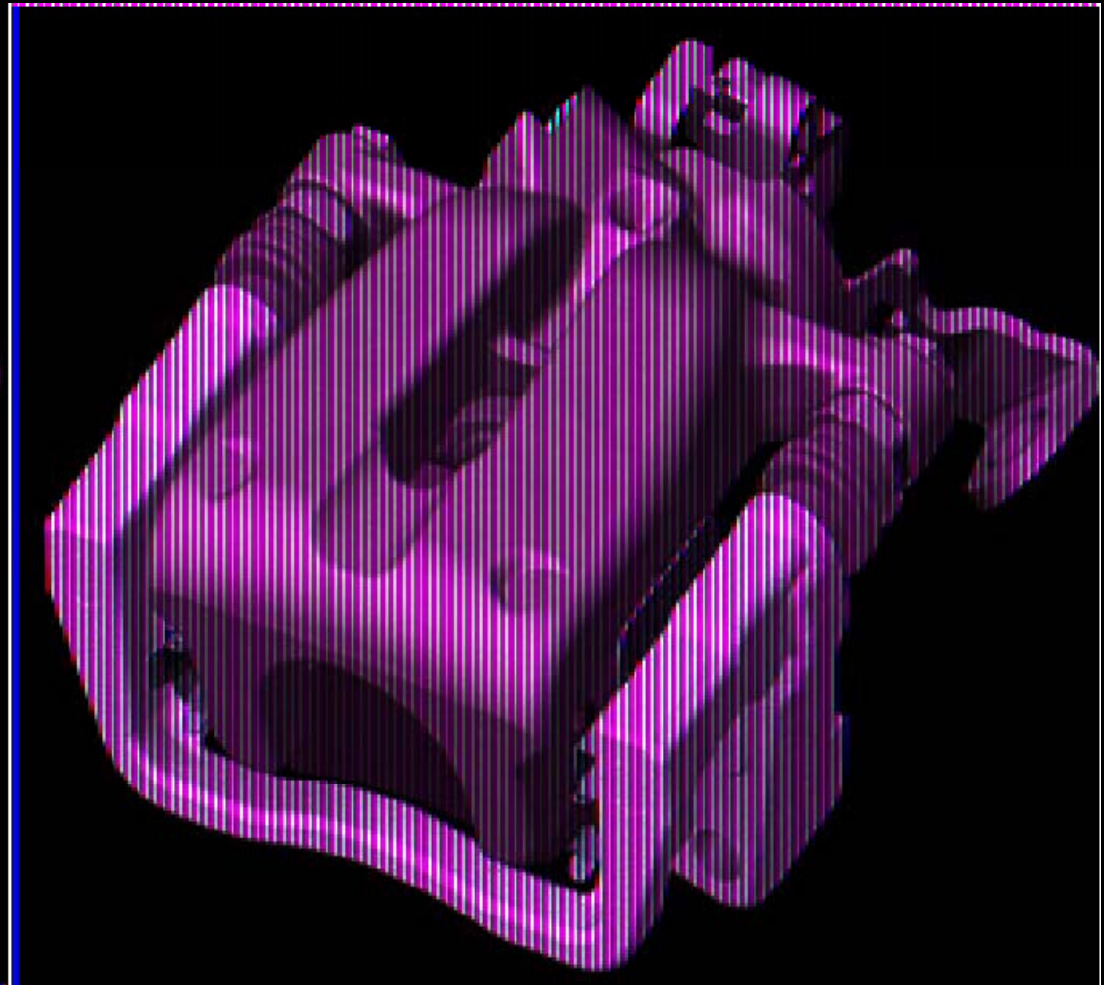

HOW ABOUT A GMC PARKING
AND EMERGENCY BRAKE ?

The Kelsey Hayes / Bendix PB Caliper:

Two of the calipers from Hayes Performance Systems, also ball ramp design and 2.6" dia. piston



HOW ABOUT A GMC PARKING
AND EMERGENCY BRAKE ?

The Kelsey Hayes / Bendix PB Caliper

MASTER CYLINDER REQUIREMENTS:

Prior to fitting the Kelsey Hayes calipers to our rearmost wheel set in the summer of 2010, we had 80 mm calipers on the front and on the intermediate wheel set and OEM drums on the rear so we had a park brake. A week before the DuQuoin IL fall rally I installed the KH park brake calipers on the rear , Fearing I might overrun the capacity of the OEM master cylinder, I "chickened out" and reinstalled a new set of 70 mm calipers (WHICH ARE ACTUALLY 74.6 MM) on the intermediate wheel set. Very gingerly bled the whole system and found the brake petal height good. Off to DuQuoin whilst the paint dried on all the new components, sporting a set of 80 mm, 74.6mm and 66mm calipers: front , centre and rear respectively and an OEM master cylinder

HOW ABOUT A GMC PARKING
AND EMERGENCY BRAKE ?

Disc Brake Master Cylinder Requirements:

- Lets look at master cylinder requirements as pertaining to disc brakes. I always thought it unfortunate to spent upwards of \$1500 for various disc brake upgrades and then install a higher volume master cylinder that results in you having 18 to 28 % LESS hydraulic braking force with reference to the OEM master cylinder than before you started.

Disc Brake Master Cylinder Requirements:

Master Cylinder Pressure Available

M / C Piston Dia.	1 - 1/8"	1 - 1/4"	1 - 5/16"	34 mm Dia.	40 mm Dia.	40 mm HB
	1.125" Dia.	1.250" Dia.	1.313" Dia.	34 mm Dia.	40 mm Dia.	40 mm HB
M / C Pressure Out	1000 PSI	815 PSI	725 PSI	710 PSI	513 PSI	1027 PSI
Percent loss in output pressure compared to 1-1/8" M/C Piston	0.0 % LOSS	18.5 % LOSS	27.5 % LOSS	29.0 % LOSS	48.7 % LOSS	2.7 % GAIN

HOW ABOUT A GMC PARKING
AND EMERGENCY BRAKE ?

Disc Brake Master Cylinder Requirements:

- **Requirement #1:** To convert the force of our foot on the brake pedal to hydraulic pressure via the piston(s) in the master cylinder (MC) to supply our calipers.
- **Requirement #2:** To contain enough fluid to enable one to completely wear out all friction material on the brake pads and still have some fluid in the MC reservoir(s). An SAE decree from the 1960's

Master Cylinder(MC) Requirement #1:

In our case of running 6 wheel discs with an OEM MC with 80mm, 74.6mm and 66mm calipers front to back respectively and still have an adequate brake pedal height, how is that possible ? The deciding factor is a phenomenon known as caliper "piston knockback".

Let's review the common causes of excessive brake pedal movement and reserve "piston knockback" for last.

Disc Brake Master Cylinder Requirements: regarding common causes of " low" pedal

- Friction material clearances
- Design clearances and wear in linkages
- Swelling of hydraulic hoses
- Slight compression of hydraulic fluid
- Compression of air bubbles in hyd. fluid
- Bending of pedal, linkage or brackets
- Deflection of calipers, drums, backing plates or caliper mounts

Caliper "piston knockback" causes

- Caliper "piston knockback" issues are greater than all the previous mentioned " low petal" factors put together. There are a number of reasons for piston knockback:
 - Brake rotor lateral " runout"
 - Wheel bearing slackness, misadjusted bearings
 - Normal piston retraction via square piston seal
 - Caliper " Bridge" deflection
 - Sticking of caliper on its rails or slide pins.
 - Bent wheel spindles

Caliper “piston knockback” Issues

- The largest factor of all contributing to caliper piston knockback and accompanying low brake pedal and needing larger and larger master cylinder pistons is brake caliper mounting plate flex. Two factors are prevalent here:
 - #1/ The caliper itself flexing in its mount.
 - #2/ The caliper mount flexing relative to its attachment point on the spindle.

Caliper Piston Knockback Issues

Observe the bearing surface where the caliper impacts on its mount upon brake application. ie. 3/8" and approx. 2" out from the C/L of the brake rotor.

As the brake is applied the first thing that happens is the caliper cocks in its mount and secondly the whole mount begins to flex.

This setup MIGHT be OK for an automobile with 500 to 800 pounds per wheel but is woefully inadequate for combatting undue flex / cocking at 2000 pounds per wheel on a GMC Motorhome.



HOW ABOUT A GMC PARKING
AND EMERGENCY BRAKE ?

Caliper "piston knockback" Issues

Caliper Mounting—It is essential that a caliper not move or flex as the brakes are applied—other than the lateral movement of a floating caliper. If the caliper-mounting structure is flexible, the caliper can twist on its mount. This causes uneven pad wear, a spongy pedal and excessive pedal movement.

A common race-car design error is using thin, flexible brackets to mount the caliper to the spindle. Because the

rotor and caliper-mounting bracket lie in two different planes, the caliper bracket has a twisting force on it when the brakes are applied. If the bracket is too thin, it will twist, cocking the caliper against the rotor. Generally, a mounting bracket at least 1/2-in. thick should be used, particularly on large race cars such as stock cars.

Caliper "piston knockback" Issues

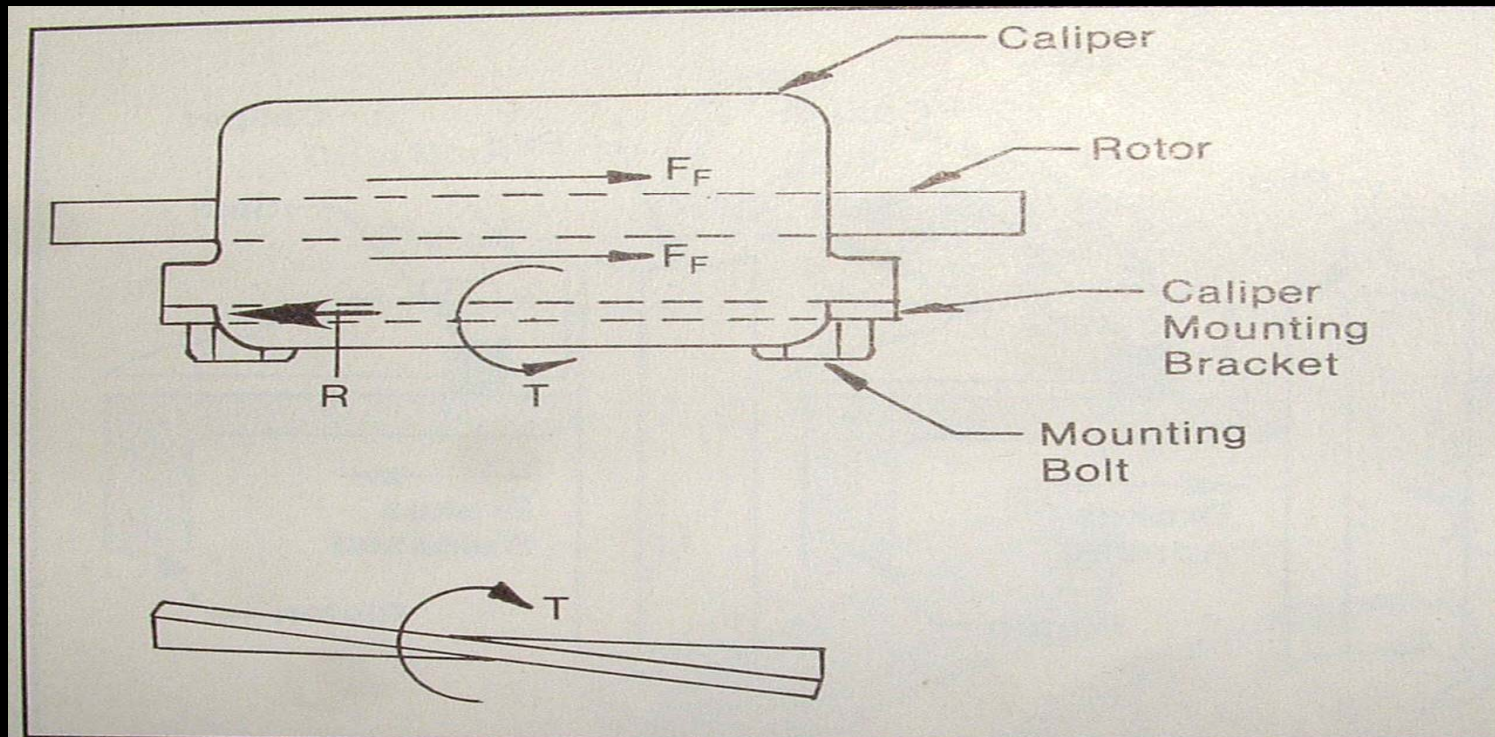

Forces on brake pads, indicated by F_F , are resisted by a force R at caliper bracket. Because force R is not in line with the rotor, twisting torque T is also applied to the bracket. Effect of twisting torque on the bracket is shown in lower drawing. If mounting bracket is not sufficiently rigid, caliper cocks against rotor, causing uneven pad wear, spongy pedal, and excessive pedal movement. Use a stiff caliper bracket and this will not happen.

HOW ABOUT A GMC PARKING
AND EMERGENCY BRAKE ?

Caliper "piston knockback" Issues

Fred Puhn is a mechanical eng. And spent a lifetime designing and researching brake systems for mainly racing applications but also for the North American domestic market as well.

This book is currently out of print but is readily available as a download from the internet as is a second book that he had published in the mid. '80,s.

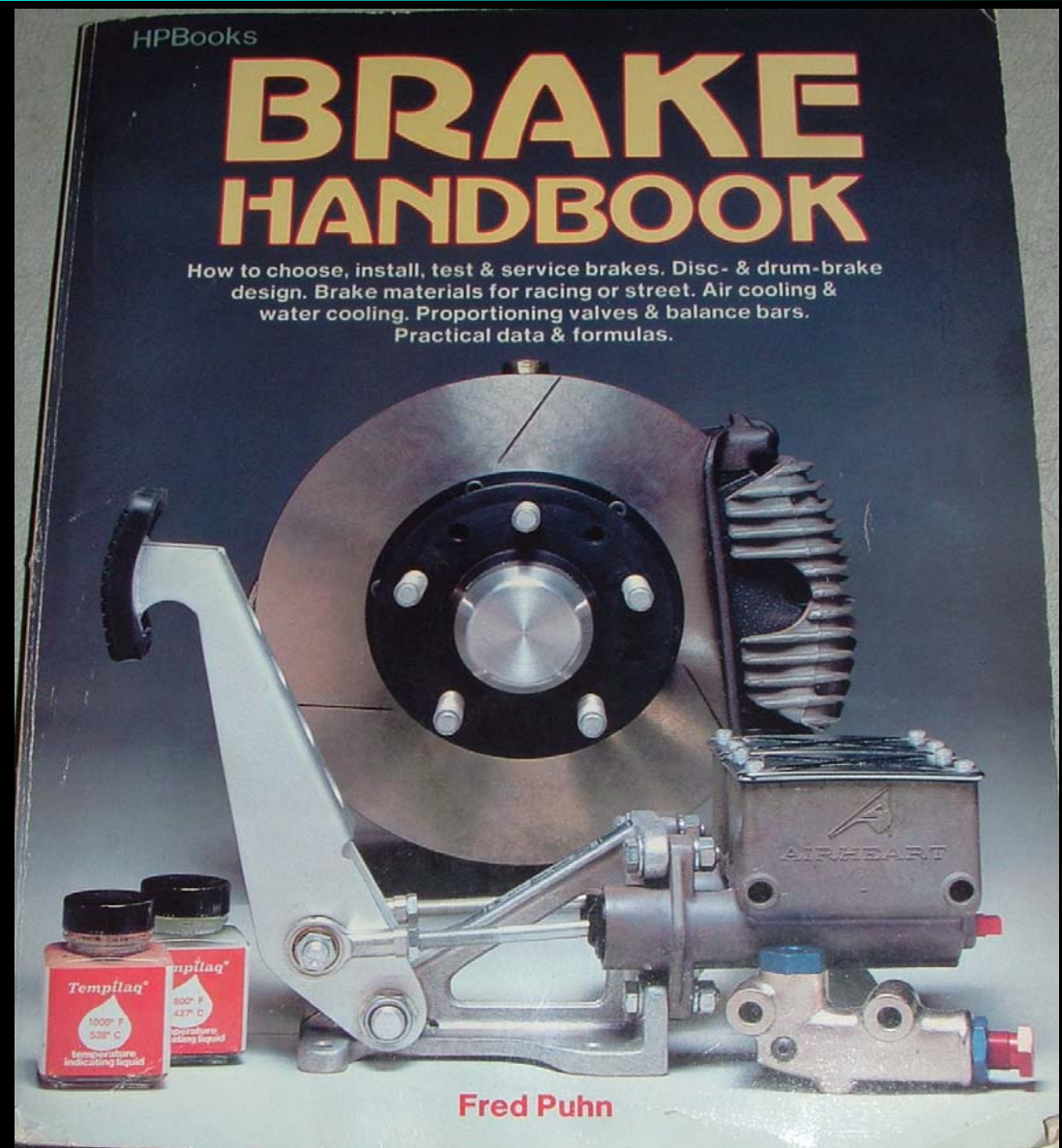

HOW ABOUT A GMC PARKING
AND EMERGENCY BRAKE ?

Caliper "piston knockback" Issues



HOW ABOUT A GMC PARKING
AND EMERGENCY BRAKE ?

Caliper "piston knockback" Issues:

Below is the caliper mount we have on our intermediate wheel set for our (70 mm)74.6 mm calipers, have had 80mm calipers on it also.



Backing plate for Toro / Eldorado type calipers, fork design similar to drop forged front knuckle

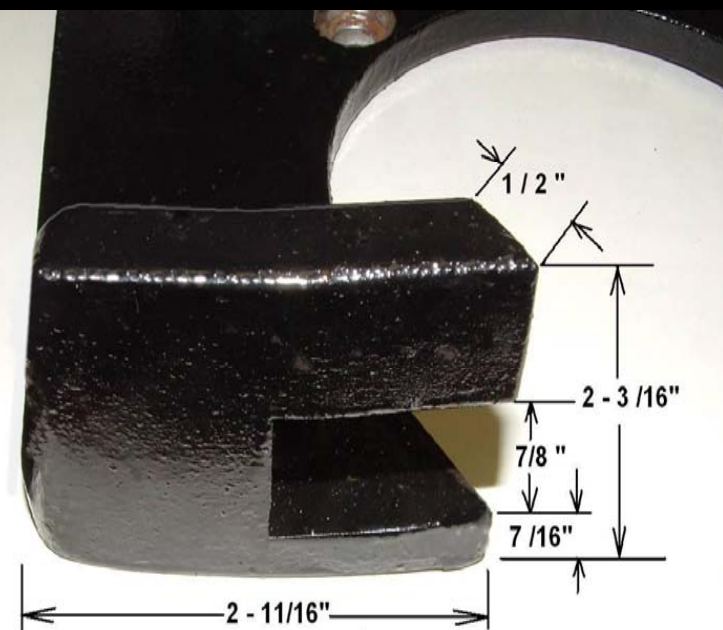

HOW ABOUT A GMC PARKING
AND EMERGENCY BRAKE ?

Caliper "Piston Knockback" Causes:

Inasmuch as caliper cocking and caliper mount flex can be greatly reduced by "rigid" and "tough" mounting systems with the accompanying reduction in master cylinder piston size we are still faced with the dilemma as what to do about fluid capacity of the master cylinder.

HOW ABOUT A GMC PARKING
AND EMERGENCY BRAKE ?

Master Cylinder (MC) Issues :

- In keeping with the " intent" of the SAE rules, guidelines, etc. **" THAT THERE SHALL BE RESERVE FLUID CAPACITY IN THE MC TO ALLOW ALL FRICTION MATERIAL TO BE WORN AWAY AND THERE STILL BE FLUID IN THE MC."**

When it comes to our motorhomes with 6 wheel discs ; THIS PREMIS MAY BE IMPOSSIBLE TO ACHIEVE !

Master Cylinder (MC) Issues:

- With 6 wheel discs and the accompanying 12 brake pads at 0.400" thick friction material and 6 pistons with an average of 6.6 square inches per piston (2 each of 80mm, 74.6mm/OEM and 66mm KH) .
- $6.6 \text{ in./sq.} \times 0.800" \times 6 \text{ wheels} = 31.68 \text{ in. cu.}$! "WOW ! " That's just over half a liter of MC fluid capacity required.

Master Cylinder (MC) Issues:

The Wilwood MC to the right has one of the larger reservoirs going and as you can see it has a total capacity of 13.93 in. cu. + 8.43 in. cu. For a total of 22.36 in. cu. Only just over 2/3's of the capacity required to run the friction material to the metal.

This large capacity MC will not satisfy the SAE requirement, that by the time the vehicle driver hears metal to metal contact in his braking system, it might twig him to say " WOW ! Perhaps I should check my brake fluid level in the MC ! "

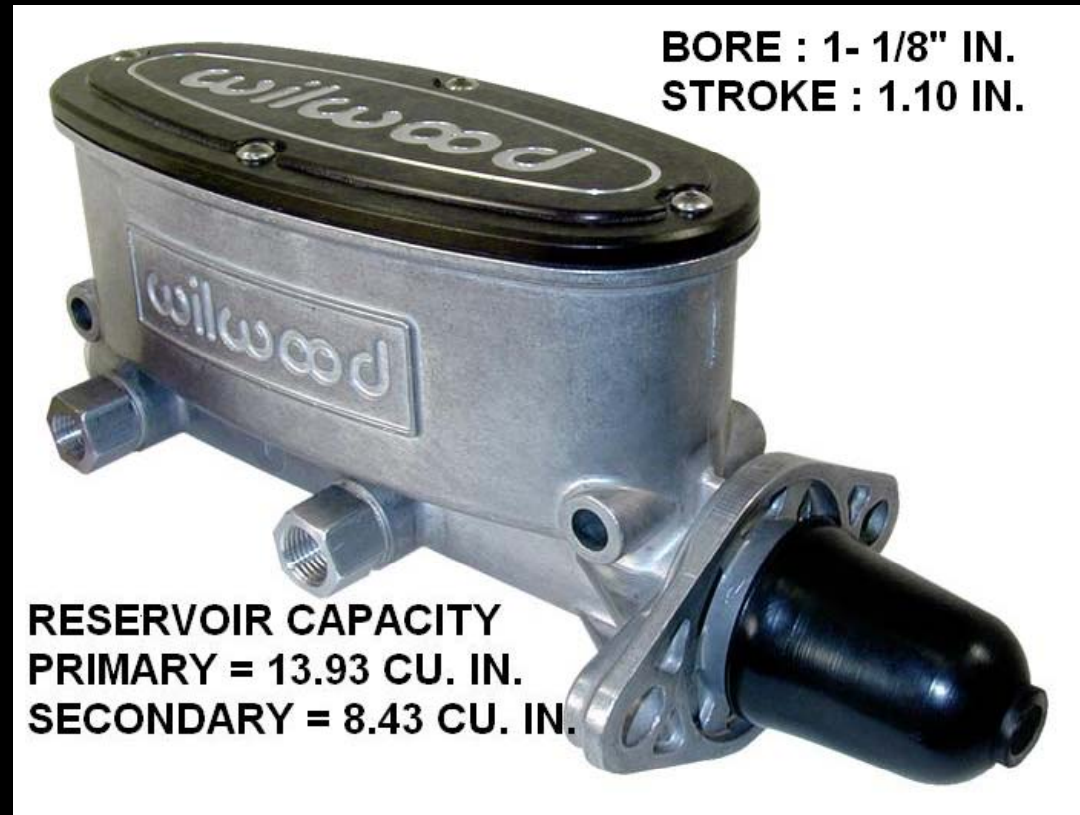

HOW ABOUT A GMC PARKING
AND EMERGENCY BRAKE ?

Master Cylinder (MC) Issues:

This dilemma needs further research and will keep you posted when it's available.

There are no handouts available but this powerpoint presentation will be posted on our website and can be copied in whole or in part without permission .

CHEERS and THANK YOU:

Albert Branscombe

branscoa@bmts.com

www.bdub.net/branscombe

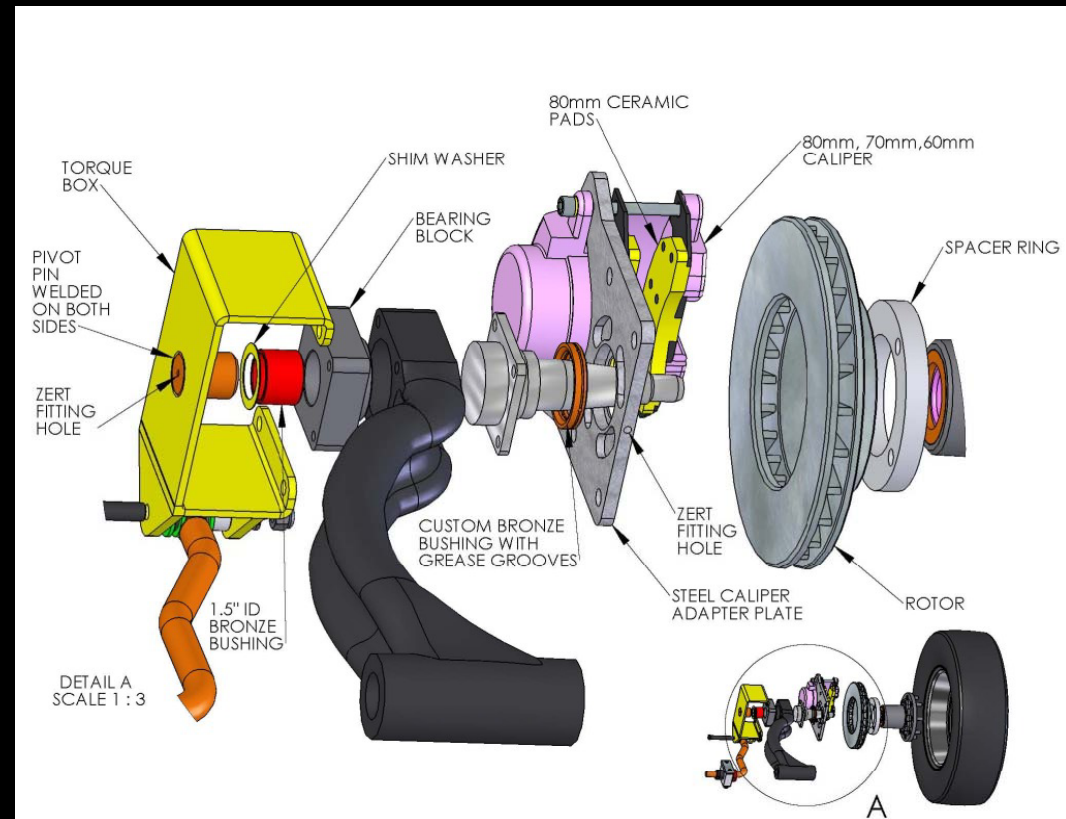

HOW ABOUT A GMC PARKING
AND EMERGENCY BRAKE ?

For Questions or Purchase Information,
see www.bdub.net/branscombe/

Or contact:

Albert Branscombe
33 Rae Street, P.O. Box 44
Tiverton , ON , N0G 2T0
CANADA

(519) 368-7129 ~ branscoa@bmts.com